

LDC

With DC motor





Olaer is a global player specialising in innovative, efficient system solutions for temperature optimisation and energy storage.

All over the world, our products are working in the most diverse environments and applications.

LDC Air Oil Coolers

- For mobile use - maximum cooling capacity 30 kW

The LDC air oil cooler with 12 or 24 V DC motor is optimized for use in the mobile industry. Together with a wide range of accessories, the LDC cooler is suitable for installation in most applications and environments. The maximum cooling capacity is 30 kW at ETD 40°C. Choosing the right cooler requires precise system sizing. The most reliable way to size is with the aid of our calculation program. This program, together with precise evaluations from our experienced, skilled engineers, gives you the opportunity for more cooling per € invested.



Overheating - an expensive problem

An under-sized cooling capacity produces a temperature balance that is too high. The consequences are poor lubricating properties, internal leakage, a higher risk of cavitation, damaged components, etc. Overheating leads to a significant drop in cost-efficiency and environmental consideration.

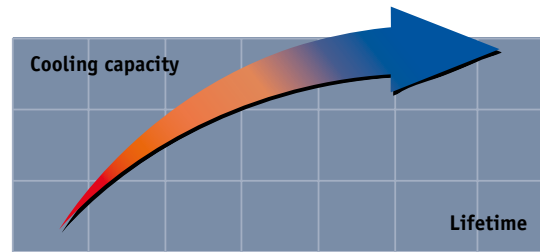

Temperature optimisation - a basic prerequisite for cost-efficient operation

Temperature balance in a hydraulic system occurs when the cooler can cool down the energy input that the system does not consume - the system's lost energy ($P_{loss} = P_{cool} = P_{in} - P_{used}$).

Temperature optimisation means that temperature balance occurs at the system's ideal working temperature - the temperature at which the oil's viscosity and the air content comply with recommended values. The correct working temperature produces a number of economic and environmental benefits:

- The hydraulic system's useful life is extended.
- The oil's useful life is extended.
- The hydraulic system's availability increases - more operating time and fewer shutdowns.
- Service and repair costs are reduced.
- High efficiency level maintained in continuous operation - the system's efficiency falls if the temperature exceeds the ideal working temperature.

Clever design and the right choice of materials and components produce a long useful life, high availability and low service and maintenance costs.

Compact design and low pressure drop and high cooling capacity.

Easy to maintain and easy to retrofit in many applications.



DC motor
12V/24V

Quiet
fan and fan motor.

Compact design and
low weight.

Smart DC Drive

Smart DC Drive for soft start of fan, as well as lower power consumption and sound level by means of temperature-controlled speed regulation. Smart DC Drive also eliminates voltage peaks, thus contributing towards a longer useful life for the fan motor.

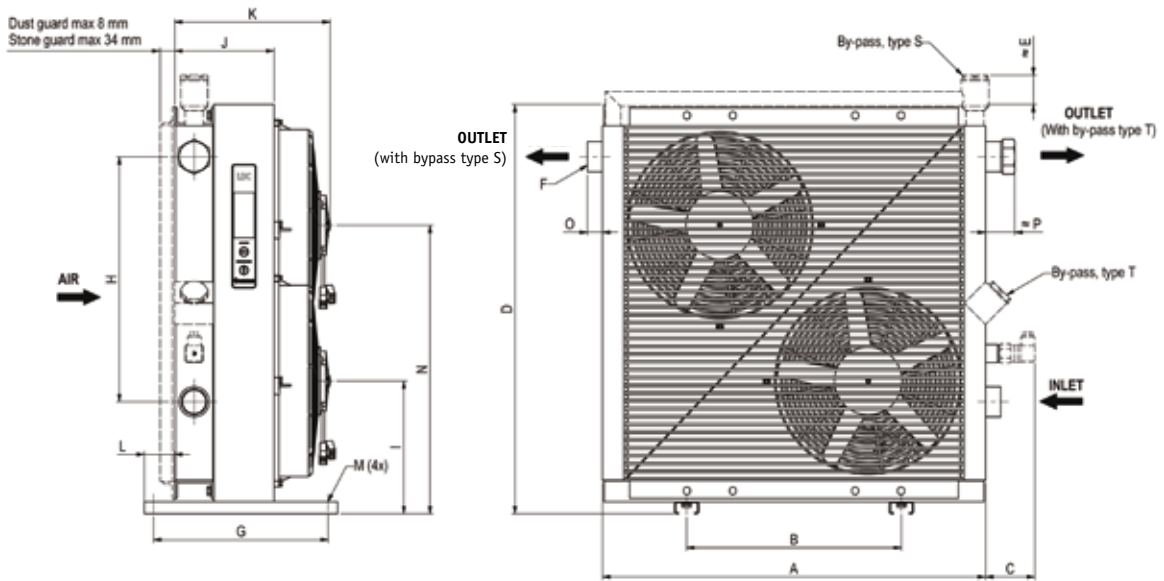

The cooling capacity curves are based on the inlet oil temperature and the ambient air temperature. An oil temperature of 60°C and an air temperature of 20 °C produce a temperature difference of 40 °C. Multiply by kW/°C for total cooling capacity.

TYPE	A	B	C	D	E	F	G	H	I	J	K	L	Mø	N	O	P	Weight kg (approx)	Acoustic Pressure LpA dB(A) 1m*
LDC 002	184	74	72	189	94	G½	187	72	100	107	157	36	9	-	11	25	4	66
LDC 003	244	134	82	227	71	G1	146	90	118	102	147	26	9x14	-	23	35	5	68
LDC 004	267	134	82	253	72	G1	146	90	131	107	152	26	9x14	-	23	35	6	68
LDC 007	330	203	82	338	59	G1	267	160	173	105	170	57	9	-	23	44	9	71
LDC 011	400	360	82	396	65	G1	101	230	200	125	218	-	9x29	-	23	44	12	74
LDC 016	464	416	82	466	63	G1	101	300	235	125	128	-	9x29	-	23	44	15	74
LDC 020	510	470	82	510	61	G1	101	280	257	125	211	-	9x29	-	23	44	18	77
LDC 023	615	356	46	635	26	G1	290	305	200	125	218	50	13	455	-	8	25	77
LDC 033	635	356	82	678	59	G1¼	290	406	220	165	258	50	13	478	25	49	30	77

* = Noise level tolerance ± 3 dB(A)

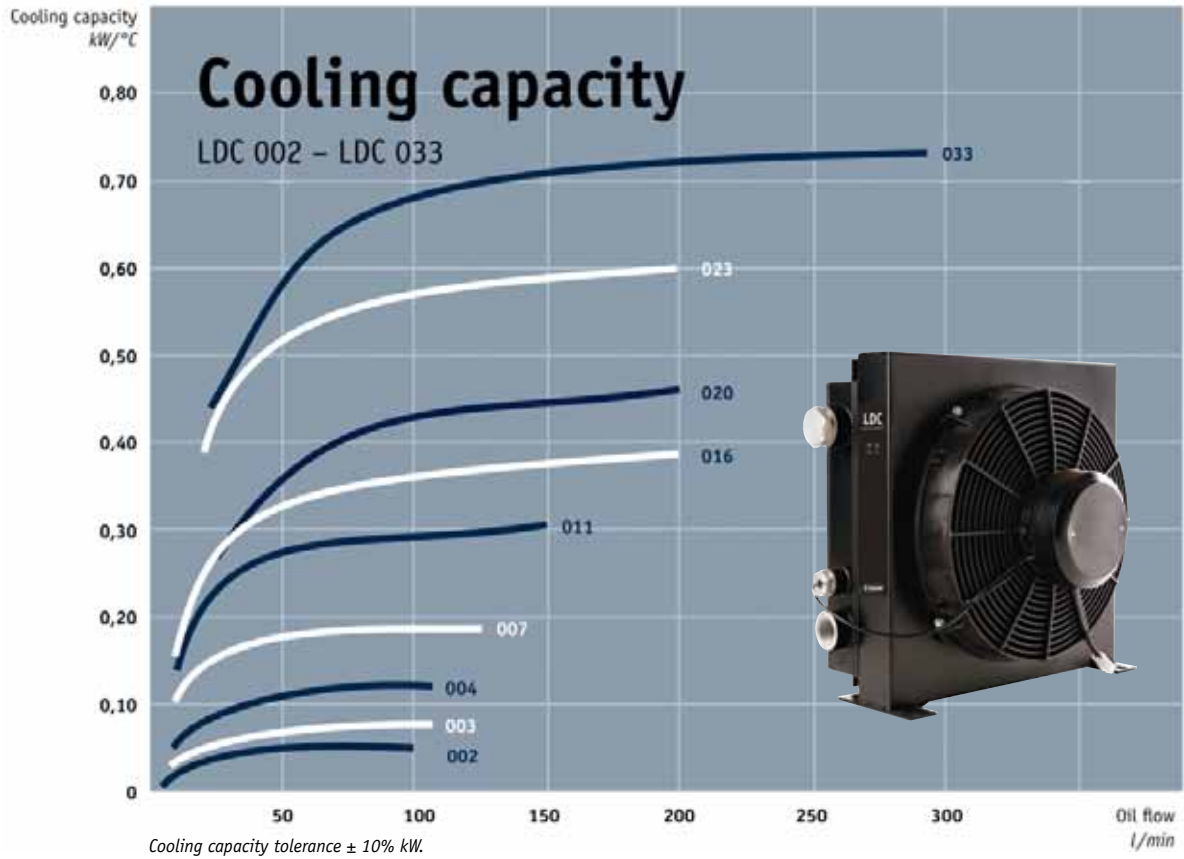

Key for LDC air oil coolers

All positions must be filled in when ordering

EXAMPLE:

LDC - 016 - A - S - 00 - S20 - S - 0

1 2 3 4 5 6 7 8

1. AIR OIL COOLER

WITH DC MOTOR = LDC

2. COOLER SIZE

002, 003, 004, 007, 011, 016, 020, 023, 033

3. MOTOR VOLTAGE

12 V = A

24 V = B

4. ACCESSORIES FOR DC MOTOR

No motor accessories = 0

Smart DC Drive, incl. temperature indicator 50°C = S

Relay box = C

5. THERMO CONTACT

No thermo contact = 00

40 °C = 40

50 °C = 50

60 °C = 60

70 °C = 70

80 °C = 80

90 °C = 90

6. COOLER MATRIX

Standard = 000

Two-pass = T00

Built-in, pressure-controlled bypass, single-pass

2 bar = S20

5 bar = S50

8 bar = S80

Built-in, pressure-controlled bypass, two-pass*

2 bar = T20

5 bar = T50

8 bar = T80

Built-in temperature and pressure-controlled bypass, single-pass

50 °C, 2.2 bar = S25

60 °C, 2.2 bar = S26

70 °C, 2.2 bar = S27

90 °C, 2.2 bar = S29

Built-in temperature and pressure-controlled bypass, two-pass*

50 °C, 2.2 bar = T25

60 °C, 2.2 bar = T26

70 °C, 2.2 bar = T27

90 °C, 2.2 bar = T29

* = not for LDC 002 - LDC 004

7. MATRIX GUARD

No guard = 0

Stone guard = S

Dust guard = D

Dust and stone guard = P

8. STANDARD/SPECIAL

Standard = 0

Special = Z

Technical specification

FLUID COMBINATIONS

Mineral oil	HL/HLP in accordance with DIN 51524
Oil/water emulsion	HFA, HFB in accordance with CETOP RP 77H
Water glycol	HFC in accordance with CETOP RP 77H
Phosphate ester	HFD-R in accordance with CETOP RP 77H

MATERIAL

Cooler matrix	Aluminum
Fan blades/guard	Glass fibre reinforced polypropylene
Fan housing	Steel
Other parts	Steel
Surface treatment	Electrostatically powder-coated

COOLER MATRIX

Maximum static working pressure	21 bar
Dynamic working pressure	14 bar*
Heat transfer tolerance	± 6 %
Maximum oil inlet temperature	120 °C

* Tested in accordance with ISO/DIS 10771-1

ELECTRIC MOTOR

LDC	002	003	004	007-020	023-033
Speed (rpm)	3 700	3 670	3 350	3 060	3 060
Protection std.	IP 68	IP 68	IP 68	IP 68	IP 68
Insulation class	H	H	H	H	H
Ambient temp.	-30°C - +80°C				
Power consump. (A) 12V	6.5	8	8	20	2x20*
(A) 24V	3.5	4	4	10	2x10*

* = LDC 023 and LDC 033 have two motors

Use a relay if the current load is superior to: 8 A at 12V and 6 A 24V

COOLING CAPACITY CURVES

The cooling capacity curves in this technical data sheet are based on tests in accordance with EN 1048 and have been produced using oil type ISO VG 46 at 60 °C.

CONTACT OLAER FOR ADVICE ON

Oil temperatures > 120 °C

Oil viscosity > 100 cSt

Aggressive environments

Ambient air rich in particles

High-altitude locations

CONNECTION CHART

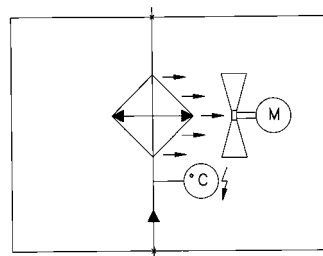

Connection chart for LDC air oil cooler.

The information in this brochure is subject to change without prior notice.



With our specialist expertise, industry knowledge and advanced technology, we can offer a range of different solutions for coolers and accessories to meet your requirements.

Take the next step

- choose the right accessories

Supplementing a hydraulic system with a cooler, cooler accessories and an accumulator gives you increased availability and a longer useful life, as well as lower service and repair costs. All applications and operating environments are unique. A well-planned choice of the following accessories can thus further improve your hydraulic system. Please contact Olaer for guidance and information.



Pressure-controlled bypass valve *Integrated*

Allows the oil to bypass the cooler matrix if the pressure drop is too high. Reduces the risk of the cooler bursting, e.g. in connection with cold starts and temporary peaks in pressure or flow. Available for single-pass or two-pass matrix design.



Smart DC Drive speed regulation

For cost-efficient operation and better environmental consideration through speed-regulated fan control – the higher the temperature, the higher the fan speed.



Temperature-controlled bypass valve *Integrated*

Same function as the pressure-controlled by-pass valve, but with a temperature-controlled opening pressure - the hotter the oil, the higher the opening pressure. Available for single-pass or two-pass matrix design.



Stone guard/Dust guard

Protects components and systems from tough conditions.



Thermo contact

Sensor with preset fix point. For temperature warnings, and for more cost-efficient operation and better environmental consideration through the automatic switching on and off of the fan motor.



Temperature-controlled 3-way valve *External*

Same function as the temperature-controlled bypass valve, but positioned externally. Note: must be ordered separately.