



External level switches

NS 1-G1/2-AM

Installation and Operation Instructions

Original instructions





Bühler Technologies GmbH, Harkortstr. 29, D-40880 Ratingen
Tel. +49 (0) 21 02 / 49 89-0, Fax: +49 (0) 21 02 / 49 89-20
Internet: www.buehler-technologies.com
E-Mail: fluidcontrol@buehler-technologies.com

Read this instruction carefully prior to installation and/or use. Pay attention particularly to all advises and safety instructions to prevent injuries. Bühler Technologies can not be held responsible for misusing the product or unreliable function due to unauthorised modifications.

All rights reserved. Bühler Technologies GmbH 2022

Document information

Document No.....BE200006
Version..... 01/2022

Contents

1	Introduction.....	2
1.1	Intended Use.....	2
1.2	Functionality.....	2
1.3	Model key.....	2
1.4	Scope of Delivery.....	2
2	Safety instructions.....	3
2.1	Important advice.....	3
2.2	General hazard warnings.....	4
3	Transport and storage.....	5
4	Installation and connection.....	6
4.1	Mechanical installation.....	6
4.2	Electrical connections.....	7
4.3	Adjusting the level contacts.....	7
4.4	Information on the correct operation of reed contacts in Bühler level switches.....	9
5	Operation and control.....	10
6	Cleaning and Maintenance.....	11
7	Service and repair.....	12
8	Disposal.....	13
9	Appendices.....	14
9.1	Technical Data.....	14
9.2	Standard pin assignment.....	15
10	Attached documents.....	16

1 Introduction

1.1 Intended Use

The NS1 level switch series serves liquid level monitoring in tanks in fluid systems. They are installed on the tank and have a visual display. Up to four switching contacts provide an electronic signal for fill level monitoring.

A medium temperature between -20 °C and 80 °C (-4 °F and 176 °C) must be maintained. The level switch must not be used in highly flammable or corrosive liquids. The medium must not contain particles, particularly metallic particles, to prevent deposits on the float or between the float and switching tube. If necessary, filter the medium.

Please refer to the technical data for the specific intended use and available material combinations.

Please refer to the type plate for your equipment configuration. In addition to the job number, this also contains the item number and type designation.

WARNING



All device models are solely intended for industrial applications. They are **not safety components**. The devices must not be used if failure or malfunction thereof jeopardises the safety and health of persons. Use in explosive areas is **prohibited**.

Any use outside the technical data and outside the areas of application specified in these instructions is considered improper use.

1.2 Functionality

The measuring tube is located inside the bypass tank with sight glass. The level switches are located inside the measuring tube. These are activated by a magnet inside the level switch float.

The level contacts are reed switches. They are mounted to a perforated rail spaced as specified in the purchase order, but can be moved.

1.3 Model key

NS 1-G1/2-AM-xx-nn-xx-xx	
Type designation	Level contacts
Connection	K NO/NC
G1/2	W Changeover (max. 2)
Tank top installation	Level measurement
Plug connection	1- 4 contacts
M3	Length
M12	280
C7	370
	500
	nnn (variable, please specify value)

Ordering example:

You require: Level switch for external installation, G1/2 connections, length L= 370 mm, M3 plug connection
2 level contacts, 1st contact 100 mm NC, 2nd contact 300 mm NO

Order NS 1-G1/2-AM-M3/370-2K L1=100 NC, L2 = 300 NO

1.4 Scope of Delivery

- Level switch
- Product documentation
- Connection/mounting accessories (optional)

2 Safety instructions

2.1 Important advice

Operation of the device is only permitted if:

- the product is used under the conditions described in the installation- and operation instruction, the intended application according to the type plate and the intended use. In case of unauthorized modifications done by the user Bühler Technologies GmbH can not be held responsible for any damage,
- when complying with the specifications and markings on the nameplates.
- the performance limits given in the datasheets and in the installation- and operation instruction are obeyed,
- monitoring devices and safety devices are installed properly,
- service and repair is carried out by Bühler Technologies GmbH,
- only original spare parts are used.

This manual is part of the equipment. The manufacturer keeps the right to modify specifications without advanced notice. Keep this manual for later use.

Signal words for warnings

DANGER	Signal word for an imminent danger with high risk, resulting in severe injuries or death if not avoided.
WARNING	Signal word for a hazardous situation with medium risk, possibly resulting in severe injuries or death if not avoided.
CAUTION	Signal word for a hazardous situation with low risk, resulting in damaged to the device or the property or minor or medium injuries if not avoided.
NOTICE	Signal word for important information to the product.

Warning signs

These instructions use the following warning signs:

	Warns of a general hazard		General notice
	Warns of voltage		Unplug from mains
	Warns not to inhale toxic gasses		Wear respiratory equipment
	Warns of corrosive liquids		Wear a safety mask
	Warns of explosive areas		Wear gloves

2.2 General hazard warnings

The equipment must be installed by a professional familiar with the safety requirements and risks.

Be sure to observe the safety regulations and generally applicable rules of technology relevant for the installation site. Prevent malfunctions and avoid personal injuries and property damage.

The operator of the system must ensure:

- Safety notices and operating instructions are available and observed,
- The respective national accident prevention regulations are observed,
- The permissible data and operational conditions are maintained,
- Safety guards are used and mandatory maintenance is performed,
- Legal regulations are observed during disposal,
- compliance with national installation regulations.

Maintenance, Repair

Please note during maintenance and repairs:

- Repairs to the unit must be performed by Bühler authorised personnel.
- Only perform conversion-, maintenance or installation work described in these operating and installation instructions.
- Always use genuine spare parts.
- Do not install damaged or defective spare part. If necessary, visually inspect prior to installation to determine any obvious damage to the spare parts.

Always observe the applicable safety and operating regulations in the respective country of use when performing any type of maintenance.

The method for cleaning the devices must be adapted to the IP protection class of the devices. Do not use cleaners which could damage the device materials.

DANGER



Toxic, corrosive gases or liquids

Gasses or liquids can be harmful to the health.

- a) If necessary, ensure a safe gas/liquid discharge.
- b) Always disconnect the gas supply when performing maintenance or repairs.
- c) Protect yourself from toxic/corrosive gasses/liquids when performing maintenance. Wear suitable protective equipment.



DANGER



Potentially explosive atmosphere

Explosion hazard if used in hazardous areas.

The device is not suitable for operation in hazardous areas with potentially explosive atmospheres.

Do not expose the device to combustible or explosive gas mixtures.

3 Transport and storage

Only transport the product inside the original packaging or a suitable alternative.

The equipment must be protected from moisture and heat when not in use. It must be stored in a covered, dry, dust-free room at room temperature.

4 Installation and connection

4.1 Mechanical installation

CAUTION



Oil leak

Damaged sight glass

Ensure the bypass tank, particularly the sight glass, is not damaged by external forces.

NOTICE



The level switch must be mounted vertically to the tank to allow the float to move freely. The mounting surface on the tank must have a minimum surface quality of $R_{max} = 6.3$. If the surface quality is inadequate, leaks may occur.

The level switches come fully assembled and can be mounted to the tank with G1/2 hollow screws.

Proceed as follows:

- Install the bypass tank (1) in the planned position:
Ensure the O-rings (4) are correctly seated in the grooves on the bypass tank.
- Insert the two G1/2 hollow screws (2) all the way through the respective G3/4 opening and firmly secure to the tank.
- The screw the two VSTI plugs (3) firmly into the G3/4 threads on the tank.

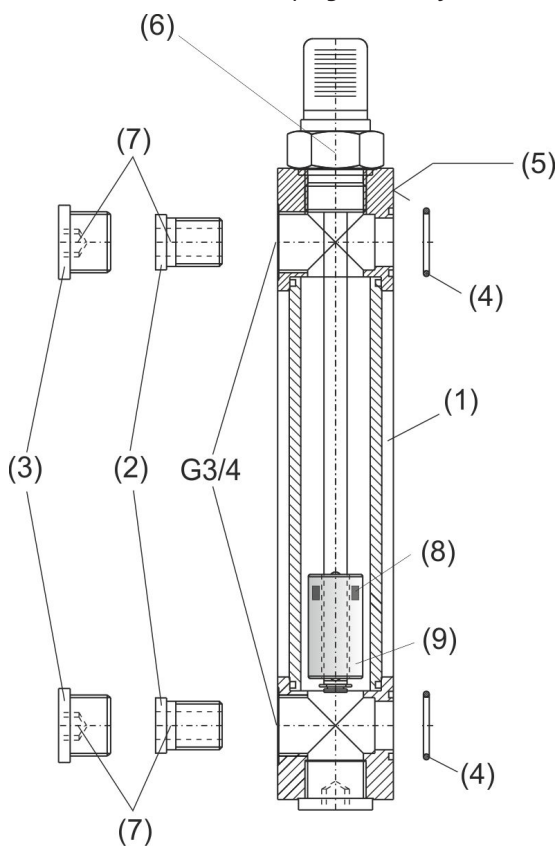

1 Bypass tank	2 G1/2 hollow screws
3 VSTI plugs	4 O-rings
5 Mounting surface (note surface quality)	6 Hexagon nut SW36
7 Spanner size SW12	8 Magnet
9 Float	

CAUTION**Oil leak****Removing the level switch**

When removing the level switch, ensure there is no fluid left in the tank or could leak from the tank.

Note: After removing the float, be sure the magnet inside the float is above the fluid level. This can easily be verified with a piece of iron to determine the magnet position inside the float.

4.2 Electrical connections

For devices with 230 V mains voltage:

DANGER**Electrical voltage**

Electrocution hazard.

- Disconnect the device from power supply.
- Make sure that the equipment cannot be reconnected to mains unintentionally.
- The device must be opened by trained staff only.
- Regard correct mains voltage.



The connection voltage is 24 V DC or 230 V AC (rated values). It connects with plugs. Please refer to the drawing in the appendix for the pin assignment.

Depending on the order specifications, the level contacts are "falling NO contact (NC)", "falling NC contact (NO)" (contact type K8) or changeover contacts (contact type W9) and mounted in the specified position. The position can be changed later (see chapter [Adjusting the level contacts](#) [> page 7]). The contact logic assumes the level switch is installed with the tank empty, meaning it is only in the operating position once the tank has been filled.

4.3 Adjusting the level contacts

The contacts for level measurement are locked into a bent rail inside the protective tube. They are positioned as specified in the purchase order, but can be moved to any position if necessary.

For devices with 230 V mains voltage:

DANGER**Electrical voltage**

Electrocution hazard.

- Disconnect the device from power supply.
- Make sure that the equipment cannot be reconnected to mains unintentionally.
- The device must be opened by trained staff only.
- Regard correct mains voltage.



- Disconnect the voltage supply.
- Disconnect the plug.
- Unscrew the plug base. For plug-in connectors with screw-in plug base, unscrew the top hexagon ring and pull the complete pin insert up until the bottom of the base can be unscrewed freely.
- Carefully pull the bent rail with contacts out the top.

NOTICE

The earth wire is a loop and soldered to the protective tube from the inside in the insertion direction. To prevent breaking off the earth wire it should not be pulled all the way out.

- Mark the original contact position.

NOTICE

Never attempt to remove the contacts from the front of the bent rail, as this will damage the glass body. Do not pull on the cables.

- Carefully slide the contacts to the desired position on the bent rail. Use a small screwdriver or similar tool to do so. Use a drop of oil if the contacts are very tight. Please note the minimum spacing!

If the contacts are configured as NO contact (NO) or NC contact (NC), the contact function can be reversed by turning the contacts 180°. There is a red mark on the housing indicating the "NO contact" function. The contact logic assumes the level switch is installed in an empty tank, i.e. it is only in the operating position once filled.

Red marking up

NO contact function
with rising level (NO)

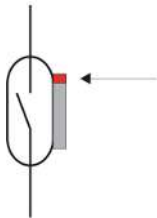

Red marking down

NC contact function
with rising level (NC)

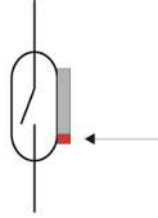

- To reverse the switching function, slide the contact out the top or bottom of the bent rail, turn 180° and slide back in, and slide into the desired position.
- If the earth wire was pulled out of the protective tube, first insert this wire into the protective tube.
- Make a loop of the additional cable length and carefully slide the bent rail back in.
- Screw on the plug base. For plugs with screw-in thread, attach the plug base clean and screw in hand tight. Leave the pin insert free so the base can turn around the cables. Now slide the cables all the way in, lock the pin insert into the guide and slide all the way in. Tighten the top hexagon ring hand tight.

4.4 Information on the correct operation of reed contacts in Bühler level switches

Based on their construction, reed contacts are very long lasting and reliable components. Yet the following should be considered when using them:

Life of reed switches

The life of reed switches can be up to 10^9 cycles. This is reduced by high stress and / or incorrect or the absence of protective circuits when switching inductive, capacitive or lamp loads.

It's therefore important to ensure NEVER to exceed one or several of the maximum approved limits, even temporarily, and to install a contact protective circuit for loads which are not purely ohmic. Using test lamps when installing the devices is also prohibited, as these can temporarily allow too much current to flow, which can damage the reed contacts. In this case non-volatile testing equipment should always be used.

Contact protective circuits for reed switches

For direct current voltage a recovery diode per figure A must be connected parallel to the contact.

For alternating current voltage an RC circuit per Figure B and Table 1 must be connected parallel to the contact.

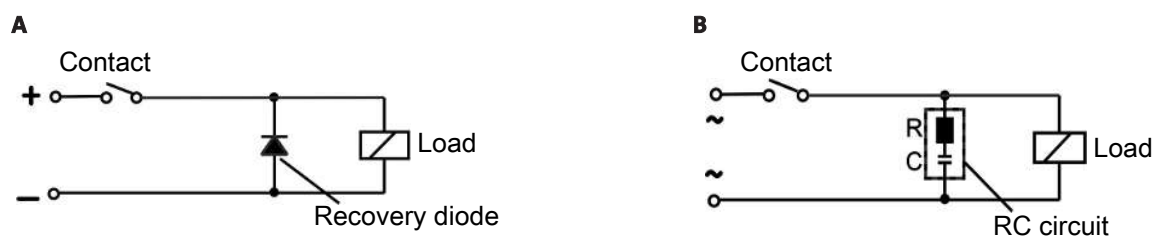

Load in VA	10		25		50		
	Voltage at contact V	R/Ohm	C/ μ F	R/Ohm	C/ μ F	R/Ohm	C/ μ F
24		22	0.022	1	0.1	1	0.47
60		120	0.0047	22	0.022	1	0.1
110		470	0.001	120	0.0047	22	0.022
230		470	0.001	470	0.001	120	0.0047

Please note the max. voltage/load ratings of the respective level contacts!

Voltages and currents

All Bühler level contacts with reed switch can switch minimal switching voltages of $10 \mu\text{V}$ and minimal switching currents of $1 \mu\text{A}$.

The maximum values specified for the respective contact types apply.

Level contact with reed switches can therefore be used for SPS applications as well as for high loads (within the maximum limits) without hesitation.

Contact material

All reed switches in Bühler level contacts use rhodium as the contact material for the actual contact areas.

Magnetic fields

Avoid external magnetic fields, including from electric motors. These can interfere with the function of the reed switches.

Mechanical loads

Do not expose the level switch to strong blows or bending.

5 Operation and control

NOTICE



The device must not be operated beyond its specifications.

6 Cleaning and Maintenance

DANGER
Toxic, corrosive gases or liquids

Gasses or liquids can be harmful to the health.

- a) If necessary, ensure a safe gas/liquid discharge.
- b) Always disconnect the gas supply when performing maintenance or repairs.
- c) Protect yourself from toxic/corrosive gasses/liquids when performing maintenance. Wear suitable protective equipment.



During maintenance, remember:

- The equipment must be maintained by a professional familiar with the safety requirements and risks.
- Only perform maintenance work described in these operating and installation instructions.
- When performing maintenance of any type, observe the respective safety and operation regulations.
- The method for cleaning the devices must be adapted to the IP protection class of the devices. Do not use cleaners which could damage the device materials.

Regularly check the bypass valve and remove any deposits to keep the float clear. Clean the sight glass as necessary.

No other maintenance required.

7 Service and repair

This chapter contains information on troubleshooting and correction should an error occur during operation.

Repairs to the unit must be performed by Bühler authorised personnel.

Please contact our Service Department with any questions:

Tel.: +49-(0)2102-498955 or your agent

If the equipment is not functioning properly after correcting any malfunctions and switching on the power, it must be inspected by the manufacturer. Please send the equipment inside suitable packaging to:

Bühler Technologies GmbH

- Reparatur/Service -

Harkortstraße 29

40880 Ratingen

Germany

Please also attach the completed and signed RMA decontamination statement to the packaging. We will otherwise be unable to process your repair order.

You will find the form in the appendix of these instructions, or simply request it by e-mail:

service@buehler-technologies.com.

8 Disposal

Dispose of parts so as not to endanger the health or environment. Follow the laws in the country of use for disposing of electronic components and devices during disposal.

9 Appendices

9.1 Technical Data

Basic Unit

Operating pressure:	max. 1 bar
Operating temperature:	-20 °C to +80 °C
Min. fluid density:	0.80 kg/dm ³
Lengths:	280, 370, 500 mm (standard) variable to max. 800 mm
Weight at L = 280 mm:	approx. 2.75 kg
Extra per 100 mm:	approx. 0.25 kg

Material

Housing:	Anodised aluminium
Sight glass:	Plexiglas (PMMA)
Fixing screws:	Chromated steel
Seal:	NBR
Level switch	Brass
Float:	NBR

Level contacts	K8	W9
Function:	NO/NC*	Changeover contact
Max. operating voltage:	230 V	48 V
Max. switching current:	0.5 A	0.5 A
Max. contact load:	10 VA	20 VA
Min. contact spacing:	40 mm	40 mm

*NO= falling NC contact/NC = falling NO contact

Dimensions

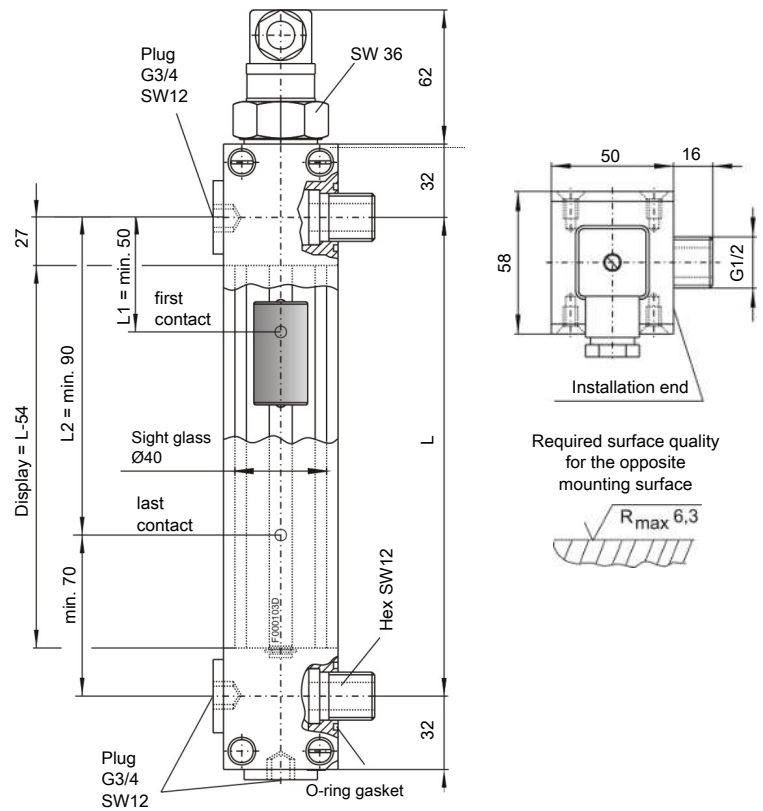

9.2 Standard pin assignment

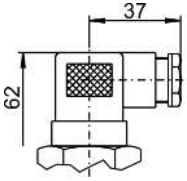
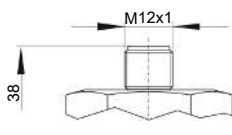
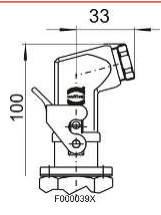
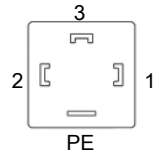
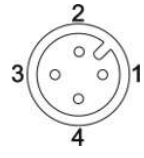
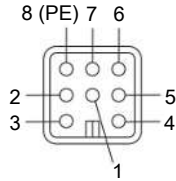
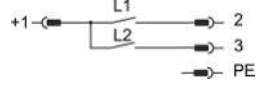
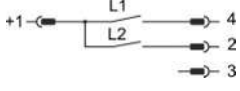
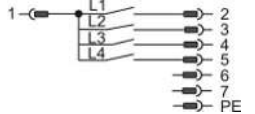
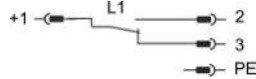
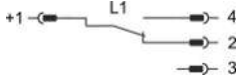
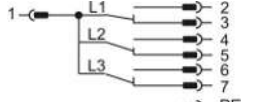
Connector:	M3 valve connector	M12 plug A-coded	C7 HAN 3 A
Dimensions:			
Connection schematic:			
Number of poles:	3-pin + PE	4-pin	7-pin + PE
DIN EN	175301-803	61076-2-101	175301-801
Max. voltage:	230 V AC/DC*	30 V DC	230 V AC/DC*
IP rating:	IP65	IP67**	IP65***
Cable fitting:	PG 11		PG 11
Max. Number of level contacts:	2 x K8 1 x W9	2 x K8 1 x W9	4 x K8 3 x W9
K8 Level contact(s)			
W9 Level contact(s)			

*Max. 48 V AC/DC for change-over contact. **IP67 with cable box attached. ***IP44 with gland/without gasket.

10 Attached documents

- Declaration of Conformity KX100008
- RMA - Decontamination Statement

EU-Konformitätserklärung
EU-declaration of conformity



Hiermit erklärt Bühler Technologies GmbH,
dass die nachfolgenden Produkte den
wesentlichen Anforderungen der Richtlinie

*Herewith declares Bühler Technologies GmbH
that the following products correspond to the
essential requirements of Directive*

2014/35/EU
(Niederspannungsrichtlinie / low voltage directive)

in ihrer aktuellen Fassung entsprechen.

in its actual version.

Folgende Richtlinie wurde berücksichtigt:

The following directive was regarded:

2014/30/EU (EMV/EMC)

Produkt / products: Niveauschalter Tankeinbau / Level switch for top tank installation
Typ / type: NS1-...-AM

Das Betriebsmittel dient zur Überwachung und zur visuellen Anzeige des Füllstandes in Tanks in
Fluidsystemen.

The equipment is intended for monitoring and for visual display of the liquid level in fluid systems tanks.

Das oben beschriebene Produkt der Erklärung erfüllt die einschlägigen
Harmonisierungsrechtsvorschriften der Union:

*The object of the declaration described above is in conformity with the relevant Union harmonisation
legislation:*

EN 61010-1:2010

EN 61326-1:2013

Die alleinige Verantwortung für die Ausstellung dieser Konformitätserklärung trägt der Hersteller.
This declaration of conformity is issued under the sole responsibility of the manufacturer.

Dokumentationsverantwortlicher für diese Konformitätserklärung ist Herr Stefan Eschweiler mit
Anschrift am Firmensitz.

*The person authorized to compile the technical file is Mr. Stefan Eschweiler located at the company's
address.*

Ratingen, den 20.04.2016

Handwritten signature of Stefan Eschweiler in black ink.

Stefan Eschweiler
Geschäftsführer – Managing Director

Handwritten signature of Frank Pospiech in blue ink.

Frank Pospiech
Geschäftsführer – Managing Director

RMA-Formular und Erklärung über Dekontaminierung

RMA-Form and explanation for decontamination



RMA-Nr./ RMA-No.

Die RMA-Nummer bekommen Sie von Ihrem Ansprechpartner im Vertrieb oder Service./ You may obtain the RMA number from your sales or service representative.

Zu diesem Rücksendeschein gehört eine Dekontaminierungserklärung. Die gesetzlichen Vorschriften schreiben vor, dass Sie uns diese Dekontaminierungserklärung ausgefüllt und unterschrieben zurücksenden müssen. Bitte füllen Sie auch diese im Sinne der Gesundheit unserer Mitarbeiter vollständig aus./ This return form includes a decontamination statement. The law requires you to submit this completed and signed decontamination statement to us. Please complete the entire form, also in the interest of our employee health.

Firma/ Company

Firma/ Company

Straße/ Street

PLZ, Ort/ Zip, City

Land/ Country

Ansprechpartner/ Person in charge

Name/ Name

Abt./ Dept.

Tel./ Phone

E-Mail

Serien-Nr./ Serial No.

Artikel-Nr./ Item No.

Gerät/ Device

Anzahl/ Quantity

Auftragsnr./ Order No.

Grund der Rücksendung/ Reason for return

- Kalibrierung/ Calibration Modifikation/ Modification
- Reklamation/ Claim Reparatur/ Repair
- andere/ other

bitte spezifizieren/ please specify

Ist das Gerät möglicherweise kontaminiert?/ Could the equipment be contaminated?

- Nein, da das Gerät nicht mit gesundheitsgefährdenden Stoffen betrieben wurde./ No, because the device was not operated with hazardous substances.
- Nein, da das Gerät ordnungsgemäß gereinigt und dekontaminiert wurde./ No, because the device has been properly cleaned and decontaminated.
- Ja, kontaminiert mit:/ Yes, contaminated with:



explosiv/
explosive



entzündlich/
flammable



brandfördernd/
oxidizing



komprimierte
Gase/
compressed
gases



ätzend/
caustic



giftig,
Lebensgefahr/
poisonous, risk
of death



gesundheitsge-
fährdend/
harmful to
health



gesund-
heitsgefährlich/
health hazard



umweltge-
fährdend/
environmental
hazard

Bitte Sicherheitsdatenblatt beilegen! / Please enclose safety data sheet!

Das Gerät wurde gespült mit:/ The equipment was purged with:

Diese Erklärung wurde korrekt und vollständig ausgefüllt und von einer dazu befugten Person unterschrieben. Der Versand der (dekontaminierten) Geräte und Komponenten erfolgt gemäß den gesetzlichen Bestimmungen.

This declaration has been filled out correctly and completely, and signed by an authorized person. The dispatch of the (decontaminated) devices and components takes place according to the legal regulations.

Falls die Ware nicht gereinigt, also kontaminiert bei uns eintrifft, muss die Firma Bühler sich vorbehalten, diese durch einen externen Dienstleister reinigen zu lassen und Ihnen dies in Rechnung zu stellen.

Should the goods not arrive clean, but contaminated, Bühler reserves the right, to commission an external service provider to clean the goods and invoice it to your account.

Firmenstempel/ Company Sign

Datum/ Date

rechtsverbindliche Unterschrift/ Legally binding signature



Die Analyse defekter Baugruppen ist ein wesentlicher Bestandteil der Qualitätssicherung der Firma Bühler Technologies.

Um eine aussagekräftige Analyse zu gewährleisten muss die Ware möglichst unverändert untersucht werden. Es dürfen keine Veränderungen oder weitere Beschädigungen auftreten, die Ursachen verdecken oder eine Analyse unmöglich machen.

Bei elektronischen Baugruppen kann es sich um elektrostatisch sensible Baugruppen handeln. Es ist darauf zu achten, diese Baugruppen ESD-gerecht zu behandeln. Nach Möglichkeit sollten die Baugruppen an einem ESD-gerechten Arbeitsplatz getauscht werden. Ist dies nicht möglich sollten ESD-gerechte Maßnahmen beim Austausch getroffen werden. Der Transport darf nur in ESD-gerechten Behältnissen durchgeführt werden. Die Verpackung der Baugruppen muss ESD-konform sein. Verwenden Sie nach Möglichkeit die Verpackung des Ersatzteils oder wählen Sie selber eine ESD-gerechte Verpackung.

Beachten Sie beim Einbau des Ersatzteils die gleichen Vorgaben wie oben beschrieben. Achten Sie auf die ordnungsgemäße Montage des Bauteils und aller Komponenten. Versetzen Sie vor der Inbetriebnahme die Verkabelung wieder in den ursprünglichen Zustand. Fragen Sie im Zweifel beim Hersteller nach weiteren Informationen.

Analysing defective assemblies is an essential part of quality assurance at Bühler Technologies.

To ensure conclusive analysis the goods must be inspected unaltered, if possible. Modifications or other damages which may hide the cause or render it impossible to analyse are prohibited.

Electronic assemblies may be sensitive to static electricity. Be sure to handle these assemblies in an ESD-safe manner. Where possible, the assemblies should be replaced in an ESD-safe location. If unable to do so, take ESD-safe precautions when replacing these. Must be transported in ESD-safe containers. The packaging of the assemblies must be ESD-safe. If possible, use the packaging of the spare part or use ESD-safe packaging.

Observe the above specifications when installing the spare part. Ensure the part and all components are properly installed. Return the cables to the original state before putting into service. When in doubt, contact the manufacturer for additional information.

