

Low Pressure Filter

Pi 1975

Nominal pressure 6 bar (90 psi), nominal size 50

1. Features

High performance filters for modern hydraulic systems

- Provided for pipe installation
- Modular system
- Compact design
- Minimal pressure drop through optimal flow design
- Visual/electrical/electronic maintenance indicator
- Threaded connections
- Quality filters, easy to service
- Equipped with highly efficient glass fibre PS filter elements
- Beta rated elements according to ISO 16889 multipass test
- Elements with high differential pressure stability and dirt holding capacity
- Worldwide distribution



2. Flow rate/pressure drop curve complete filter

190 mm²/s
33 mm²/s

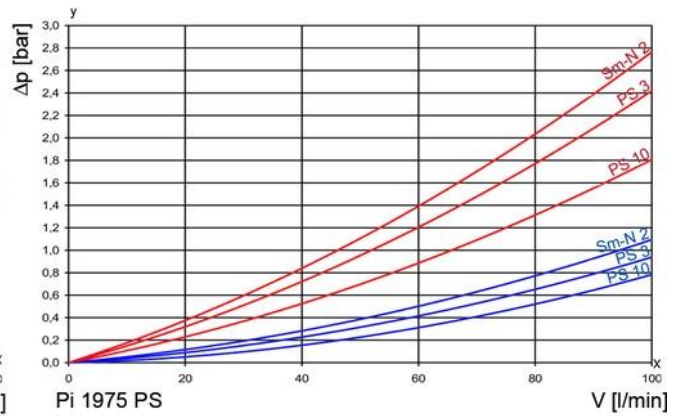
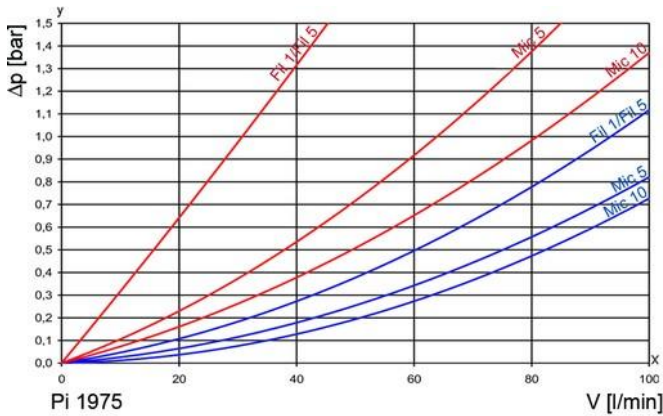

y = differential pressure Δp [bar]
x = flow rate V [l/min]

3. Separation grade characteristics

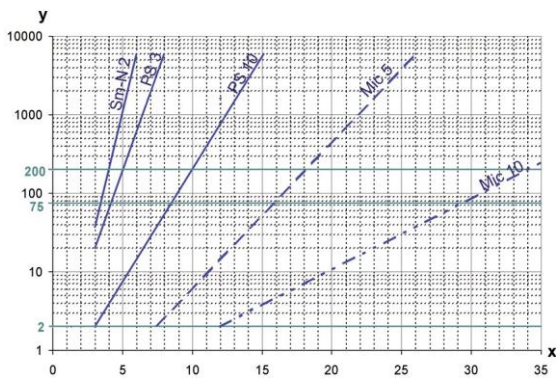

y = beta-value
x = particle size [μm]
determined by multipass tests (ISO 16889)
calibration according to ISO 11171 (NIST)

4. Filter performance data

tested according to ISO 16889 (multipass test)

PS/Sm-N 2 elements with
max. Δp 5 bar

Sm-N	2	$\beta_{4(C)} \geq 200$
PS	3	$\beta_{5(C)} \geq 200$
PS	10	$\beta_{10(C)} \geq 200$

Values guaranteed up to 5 bar differential pressure, Sm-N 2 elements up to 5 bar differential pressure.

The filter element Sm-N 2 is an element with a very large dirt holding capacity, especially for bypass filtration.

5. Quality assurance

Filtration Group filters and filter elements are produced according to the following international standards:

Norm	Designation
DIN ISO 2941	Hydraulic fluid power filter element; verification of collapse/burst resistance
DIN ISO 2942	Hydraulic fluid power filter element, verification of fabrication integrity
DIN ISO 2943	Hydraulic fluid power filter element, verification of material compatibility with fluids
DIN ISO 3723	Hydraulic fluid power filter element, method for end load test
DIN ISO 3724	Hydraulic fluid power filter element, verification of flow fatigue characteristics
ISO 3968	Hydraulic fluid power filters; evaluation of pressure drop versus flow characteristics
ISO 10771.1	Fatigue pressure testing of metal containing envelopes in hydraulic fluid applications
ISO 16889	Hydraulic fluid power filters; multipass method for evaluation filtration performance of a filter element

6. Symbols

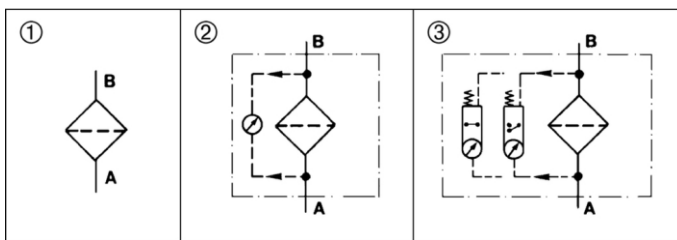

7. Order numbers

Example for ordering filters:

1. Housing design	2. Filter elements
with electrical indicator Type: Pi 1975-E Order number: 77664980	PS 10 Type: 852 275 PS 10 Order number: 77725583

7.1 Housing design

Nominal size NG [l/min]	Order number	Type	① with indicator	② with visual indicator	③ with electrical indicator
50	77664956	Pi 1975			
	77664964	Pi 1975-M			
	77664980	Pi 1975-E			

The collapse pressure of the element must not be exceeded.

7.2 Filter elements*

Nominal size NG [l/min]	Order number	Type	Filter material	max. Δp [bar]	Filter surface [cm ²]
50	77698814	852 275 Mic 5	Mic 5	5	27000
	77675903	852 275 Mic 10	Mic 10		27000
	77678121	852 275 FIL 1	FIL 1	1.4	-
	77678113	852 275 FIL 5	FIL 5		-
	79309303	852 275 Sm-N 2	Sm-N 2	5	13150
	77956220	852 275 PS 3	PS 3		15500
	77725583	852 275 PS 10	PS 10		15500

* a wider range of element types is available on request

8. Technical specifications

Design:	in-line filter
Nominal pressure:	6 bar (90 psi)
Test pressure:	8 bar (110 psi)
Temperature range:	- 10 °C to + 120 °C (other temperature ranges on request)
Filter head material:	St
Sealing material:	NBR/Cu
Maintenance indicator setting:	Δp 1.2 bar \pm 0.2 bar
Electrical data of maintenance indicator:	
Maximum voltage:	250 V AC/200 V DC
Maximum current:	1 A
Contact load:	70 W
Type of protection:	IP 65 in inserted and secured status
Contact:	normally open/closed
Cable sleeve:	M20x1.5

The switching function can be changed by turning the electric upper part by 180° (normally closed contact or normally open contact). The state on delivery is a normally closed contact. By inductivity in the direct current circuit the use of suitable protection circuit should be considered. Further maintenance indicator details and designs are available in the maintenance indicator data sheet.

We draw attention to the fact that all values indicated are average values which do not always occur in specific cases of application. Our products are continually being further developed. Values, dimensions and weights can change as a result of this. Our specialized department will be pleased to offer you advice.

We recommend you to contact us concerning applications of our filters in areas governed by the EU Directive 94/9 EC (ATEX 95). The standard version can be used for liquids based on mineral oil (corresponding to the fluids in Group 2 of Directive 97/23 EC Article 9). If you consider to use other fluids please contact us for additional support.

Subject to technical alteration without prior notice.

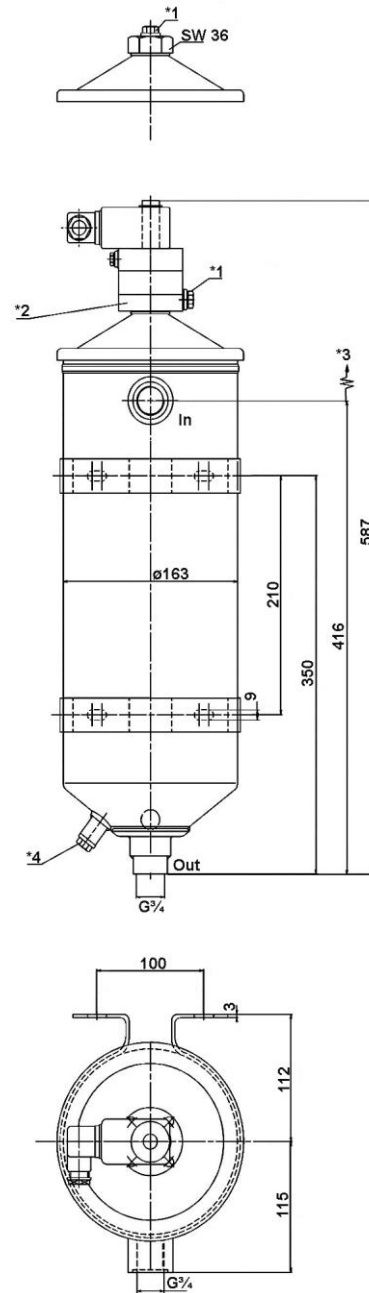

Design without indicator- weight 8 kg

*1 vent screw G $\frac{1}{4}$

*2 SW 36 for maintenance

*3 height required for element removal 400

*4 drain plug G $\frac{1}{4}$ 90° ill. turned by 90°

In = inlet

Out = outlet

9. Installation, operating and maintenance instructions

9.1 Filter installation

When installing filter make sure that sufficient space is available to remove filter element and filter housing. Preferably the filter should be installed with the filter housing pointing downwards. The maintenance indicator must be visible.

9.2 Connecting the electrical maintenance indicator

The electrical indicator is connected via a 2-pole appliance plug according to DIN EN 175301-803 with poles marked 1 and 2. The electrical section can be inverted to change from normally open to normally closed position or vice versa.

9.3 When should the filter be replaced?

1. Filters equipped with visual and electrical maintenance indicator:
During cold starts, the indicator may give a warning signal. Press the red button of the visual indicator once again only after operating temperature has been reached. If the red button immediately pops up again and/or the electrical signal has not switched off after reaching operating temperature, the filter element must be replaced after the end of the shift.
2. Filters without maintenance indicator:
The filter element should be replaced after the trial run or flushing of the system. Afterwards follow instructions of the manufacturer.
3. Please always make sure that you have original Filtration Group spare elements in stock: Disposable elements (Mic, FIL, Sm-N or PS) cannot be cleaned.

9.4 Element replacement

1. Stop system and relieve filter from pressure.
2. Remove cover screw, then lift off cover. On executions with indicator please unscrew maintenance indicator.
3. Remove filter element.
4. Check seals for damage. Replace if necessary.
5. Make sure that the order number on the spare element corresponds to the order number of the filter name-plate. Remove plastic bag and push element over the spigot in the filter housing.
6. Close drain screw, relocate cover and close it with cover screws and/or the indicator. Filters are automatically vented via the air bleeder valve. (Back off the screw 1-2 turns till medium escapes. Tight vent screw).

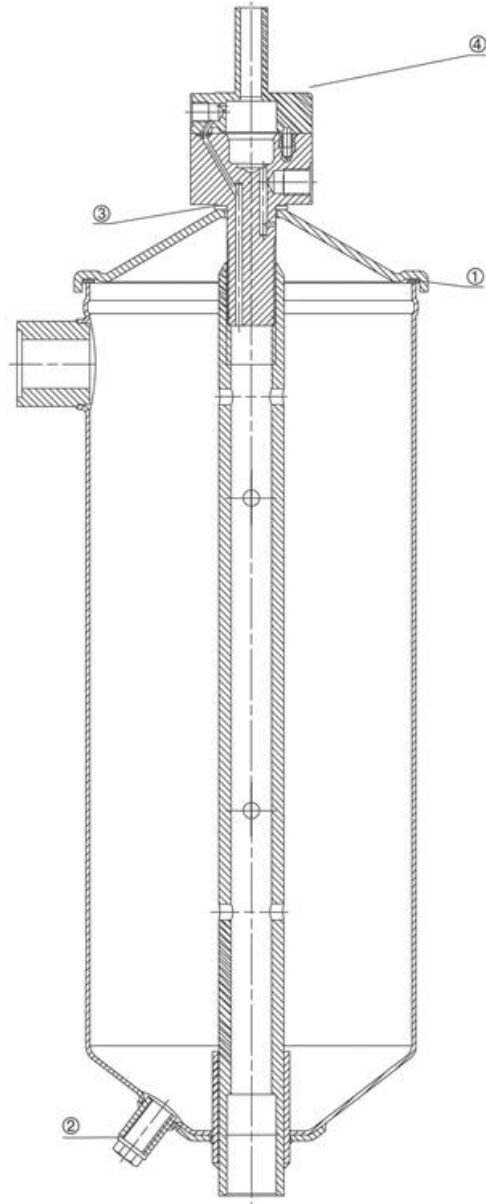

10. Spare parts list

Order number for spare parts		
Position	Type	Order number
① - ③	Seal kit for housing	
	NBR	77898836
④	Maintenance indicator	
	Visual PiS 3112/1.2	78287690
	Electrical PiS 3113/1.2	78287708
	Electrical upper section only	77536550
	Seal kit for maintenance indicator	
	NBR	78389280

Filtration Group GmbH
Schleifbachweg 45
D-74613 Öhringen
Phone +49 7941 6466-0
Fax +49 7941 6466-429
industrial.sales@filtrationgroup.com
industrial.filtrationgroup.com
78357378.03/2021
[Low Pressure Filter Pi 1975 up to NG 50](#)