

## Low Pressure Filter/Suction Filter Pi 270

Nominal pressure 16 bar (230 psi), up to nominal size 315

### 1. Features

#### High performance filters for modern hydraulic systems

- Provided for pipe installation
- Modular system
- Compact design
- Minimal pressure drop through optimal flow design
- Visual/electrical/electronic maintenance indicator
- Threaded and flange connections
- Quality filters, easy to service
- Equipped with highly efficient cellulose or glass fibre filter elements (long life)
- Beta rated elements according to ISO 16889 multipass test
- Elements with high differential pressure stability and dirt holding capacity
- Worldwide distribution



## 2. Flow rate/pressure drop curve complete filter

190 mm<sup>2</sup>/s  
33 mm<sup>2</sup>/s

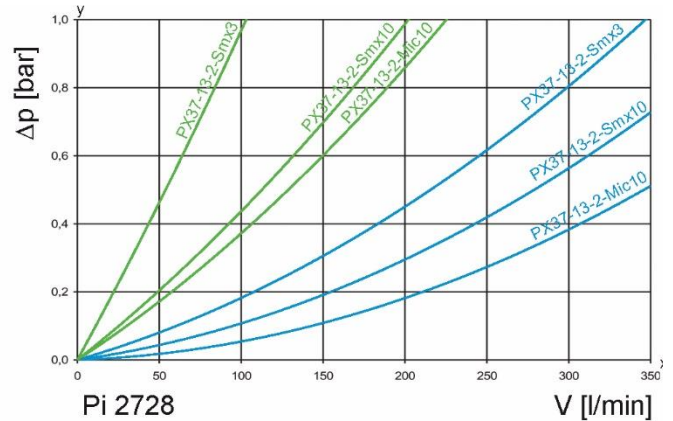
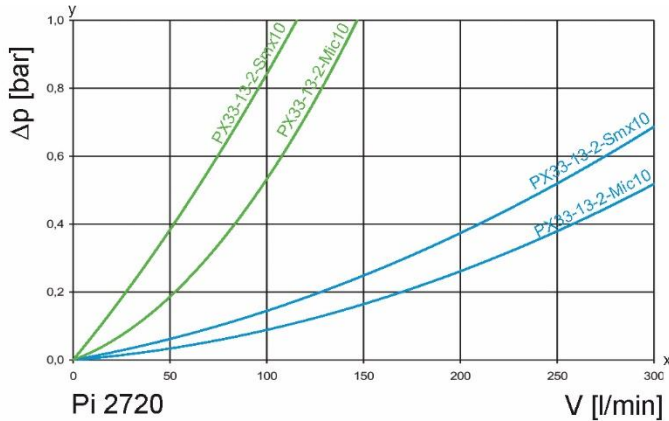

y = differential pressure  $\Delta p$  [bar]  
x = flow rate V [l/min]

## 3. Separation grade characteristics

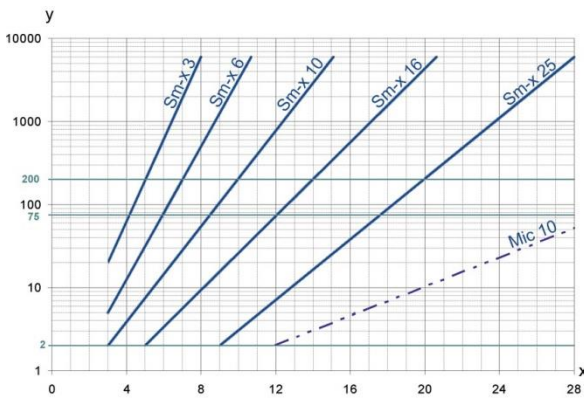

y = beta-value  
x = particle size [ $\mu\text{m}$ ]

determined by multipass tests (ISO 16889)  
calibration according to ISO 11171 (NIST)

## 4. Filter performance data

tested according to ISO 16889 (multipass test)

Sm-x elements with max.  $\Delta p$  5 bar

Sm-x 3  $\beta_{5(C)} \geq 200$   
Sm-x 10  $\beta_{10(C)} \geq 200$

values guaranteed up to 5 bar differential pressure

## 5. Quality assurance

Filtration Group filters and filter elements are produced according to the following international standards:

Norm	Designation
DIN ISO 2941	Hydraulic fluid power filter elements; verification of collapse/burst resistance
DIN ISO 2942	Hydraulic fluid power filter elements; verification of fabrication integrity
DIN ISO 2943	Hydraulic fluid power filter elements; verification of material compatibility with fluids
DIN ISO 3723	Hydraulic fluid power filter elements; method for end load test
DIN ISO 3724	Hydraulic fluid power filter elements; verification of flow fatigue characteristics
ISO 3968	Hydraulic fluid power-filters-evaluation of pressure drop versus flow characteristics
ISO 10771.1	Fatigue pressure testing of metal containing envelopes in hydraulic fluid applications
ISO 16889	Hydraulic fluid power filters-multipass method for evaluation filtration performance of a filter element

## 6. Symbols

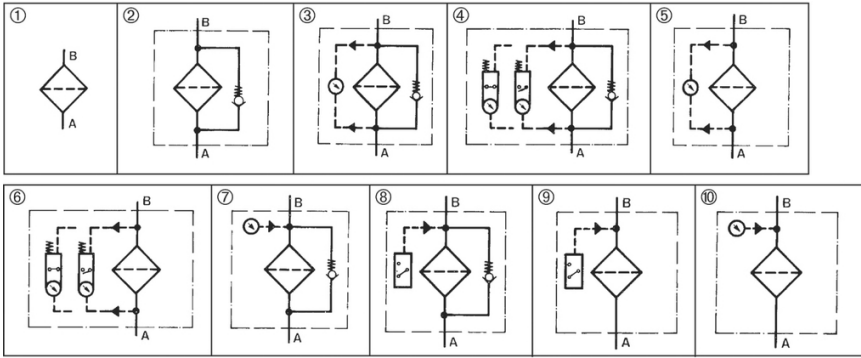

## 7. Order numbers

Example for ordering filters:

1. Filter design	2. 2x Filter elements
V = 250 l/min, bypass, electrical maintenance indicator Type: Pi 27020-058 Order number: 77694060	Mic 10 Type: PX33-13-2-Mic10 Order number: 70541525

### 7.1 Housing design/order numbers for pressure side installation \*

Nominal size NG [l/min]	Order number	Type	① no options	② with bypass 3.5 bar	③ with bypass 3.5 bar and visual indicator	④ with bypass 3.5 bar and electrical indicator	⑤ with visual indicator	⑥ with electrical indicator
250	77694011	Pi 2720-060						
	77694029	Pi 2720-056						
	77694078	Pi 2720-057						
	77694060	Pi 2720-058						
	77694045	Pi 2720-068						
	77694037	Pi 2720-069						
315	77665235	Pi 2728-060						
	77665201	Pi 2728-056						
	77665219	Pi 2728-057						
	77665227	Pi 2728-058						
	77665276	Pi 2728-068						
	77665284	Pi 2728-069						

When filter with non bypass configuration is selected, the collapse pressure of the element must not be exceeded.

\* a wider range of types is available on request

### 7.2 Spin-on cartridge/order numbers for pressure side installation\*

Nominal size NG [l/min]	Order number	Type	Filter material	max. Δp [bar]	Filter surface [cm²]
250	70541525	PX33-13-2-Mic10	Mic10	5	7000
	70541523	PX33-13-2-Smx10	Smx10		3400
315	70541540	PX37-13-2-Mic10	Mic10	5	14025
	70541536	PX37-13-2-Smx3	Smx3		7638
	70541538	PX37-13-2-Smx10	Smx10		7638

### 7.3 Housing design/order numbers for suction side installation\*

Nominal size NG [l/min]	Order number	Type	① no options	② with bypass 0.25 bar	③ with bypass 0.25 bar and vacuum gauge	④ with bypass 0.25 bar and vacuum switch	⑤ with vacuum switch	⑥ with vacuum gauge
80	77694011	Pi 2720-060						
	77694094	Pi 2720-067						
	77694102	Pi 2720-062						
	77694110	Pi 2720-061						
	77694086	Pi 2720-065						
	77694052	Pi 2720-066						
125	77665235	Pi 2728-060						
	77665201	Pi 2728-067						
	77665219	Pi 2728-062						
	77665227	Pi 2728-061						
	77665276	Pi 2728-065						
	77665284	Pi 2728-066						

When filter with non bypass configuration is selected, the collapse pressure of the element must not be exceeded

### 7.4 Spin-on cartridge/order numbers for suction side installation\*

Nominal size NG [l/min]	Order number	Type	Filter material	max. Δp [bar]	Filter surface [cm <sup>2</sup> ]
80	70541525	PX33-13-2-Mic10	Mic10	5	7000
125	70541540	PX37-13-2-Mic10	Mic10	5	14025

\* a wider range of types is available on request

## 8. Technical specifications\*

Design:	in-line filter
Nominal pressure:	16 bar (232 psi)
Test pressure:	24 bar (348 psi)
Fatigue strength:	min $10^5$ Load changes at 0 – 16 bar (232 psi)
Temperature range:	-10 °C up to +120 °C (other temperature ranges on request)
Bypass setting:	
Pressure side:	$\Delta p$ 3.5 bar $\pm 10$ %
Suction side:	$\Delta p$ 2.5 bar $\pm 10$ %
Filter head material:	GAL
Spin-on cartridge material:	St
Sealing material:	NBR/AL
Maintenance indicator setting:	$\Delta p$ 2.2 bar $\pm 10$ %
Indicating range vacuum gauge:	-1 bar up to +1.5 bar
Pressure setting vacuum switch:	-1 bar up to +1.5 bar
Type of protection (suction side):	IP 54
Electrical data of maintenance indicator:	
Maximum voltage:	250 V AC/200 V DC
Maximum current:	1 A
Contact load:	70 W
Type of protection:	IP 65 in inserted and secured status
Contact:	normally open/closed
Cable connection:	M20x1.5

The switching function can be changed by turning the electric upper part by 180 ° (normally closed contact or normally open contact). The state on delivery is a normally closed contact. By inductivity in the direct current circuit the use of suitable protection circuit should be considered. Further maintenance indicator details and designs are available in the maintenance indicator data sheet.

We draw attention to the fact that all values indicated are average values which do not always occur in specific cases of application. Our products are continually being further developed. Values, dimensions and weights can change as a result of this. Our special-ized department will be pleased to offer you advice.

We recommend you to contact us concerning applications of our filters in areas governed by the EU Directive 94/9 EC (ATEX 95). The standard version can be used for liquids based on mineral oil (corresponding to the fluids in Group 2 of Directive 97/23 EC Article 9). If you consider to use other fluids please contact us for additional support.

\* a wider range of types is available on request

Subject to technical alteration without prior notice!

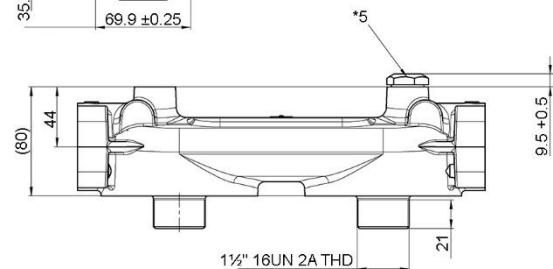
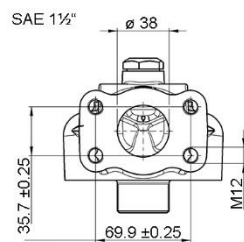
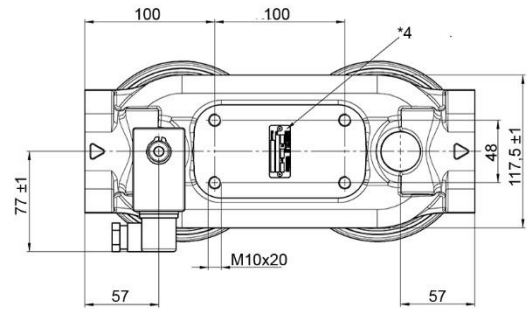
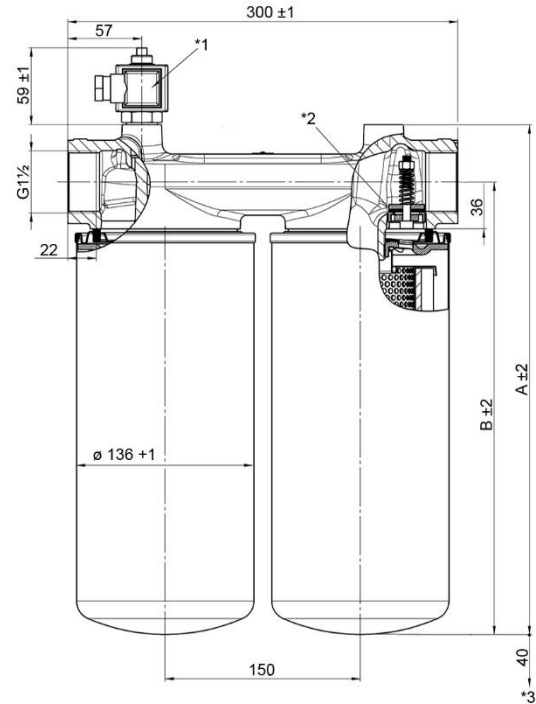

- \*1 Electrical maintenance indicator
- \*2 Bypass valve only existing at suction side design
- \*3 Clearance required
- \*4 Name plate
- \*5 Blind plug

All dimensions in mm.

Type	A	B
Pi 2720	323	279
Pi 2728	391	347

## 9. Installation, operating and maintenance instructions

### 10.1 Filter installation

When installing the filter make sure that sufficient space is available to remove spin-on cartridge. Filter should be installed with the spin-on cartridge pointing downwards. The maintenance indicator must be visible.

### 10.2 Connecting the electrical maintenance indicator

The electrical indicator is connected via a 2-pole appliance plug according to DIN EN 175301-803 with poles marked 1 and 2. The electrical section can be inverted to change from normally open position to normally closed position or vice versa. The state on delivery is a normally closed contact.

### 10.3 When should the filter element be replaced?

1. Filters equipped with visual and electrical maintenance indicator: During cold starts, the indicator may give a warning signal. Press the red button of the visual indicator once again only after operating temperature has been reached. If the red button immediately pops up again and/or the electrical signal has not switched off after reaching operating temperature, the spin-on cartridge must be replaced after the end of the shift.
2. Filters without maintenance indicator: The spin-on cartridge should be replaced after the trial run or flushing of the system. Afterwards follow instructions of the manufacturer.
3. Please always ensure that you have original Filtration Group spare spin-on cartridges in stock.

### 10.4 Spin-on cartridge replacement

1. Stop system and relieve filter from pressure.
2. Unscrew the spin-on cartridge by using a filter wrench by turning counter-clockwise.
3. Make sure that the order number on the spin-on cartridge corresponds to the order number of the filter plate.
4. Oil the seal of the spin-on cartridge.
5. Spin-on cartridge must be installed according to the printed instructions.

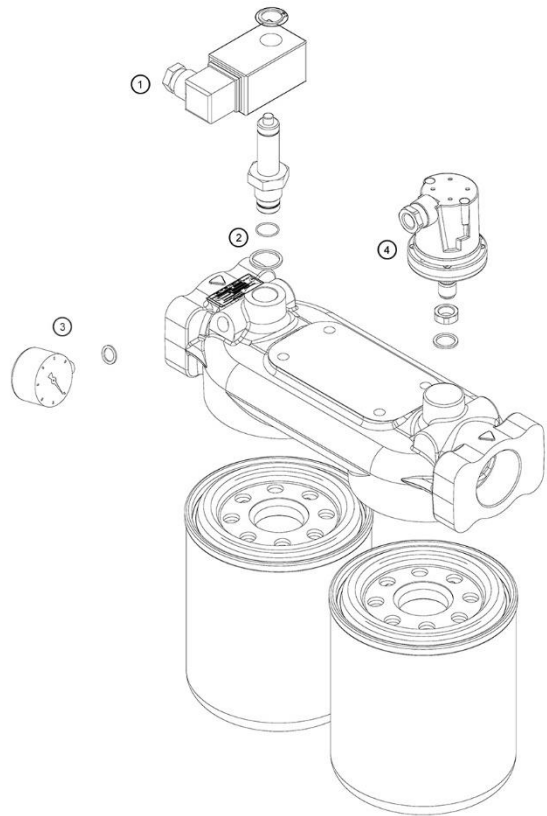

## 10. Spare parts list

Order numbers for spare parts		
Position	Type	Order number
①	Maintenance indicator	
	Visual PiS 3098/2,2	77669971
	Electrical PiS 3097/2,2	77669948
	Electrical upper section only	77536550
②	Seal kit for maintenance indicator	
	NBR	77760309
③	Vacuum gauge	76345763
④	Vacuum switch PiS 3070/200 mbar	77669724