

Tank Top Return-Line Filter Pi 530

Nominal size 35 and 50

1.Features

High performance filters for modern hydraulic systems

- Provided for tank top installation
- Modular system
- Compact design
- Minimal pressure drop through optimal flow design
- Visual/electrical/electronic maintenance control
- Threaded alt. hose connections
- Quality filters, easy to service
- Equipped with highly efficient glass fibre Sm-x filter
- Beta rated elements according to ISO 16889 multipass test
- Elements with high differential pressure stability and dirt holding capacity
- Worldwide distribution



2. Flow rate/pressure drop curve complete filter

■ 190 mm²/s
■ 33 mm²/s

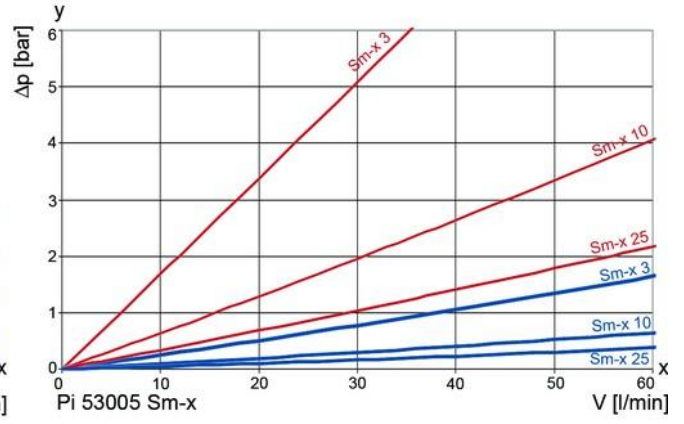
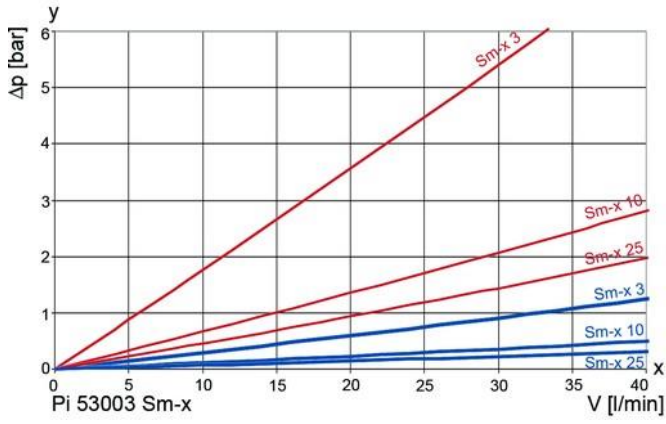

y = differential pressure p [bar]

x = flow rate V [l/min]

3. Separation grade characteristics

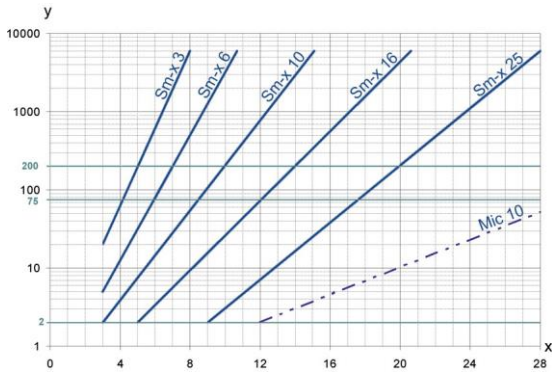

y = beta-value

x = particle size [μm]

determined by multipass tests (ISO 16889)

calibration according to ISO 11171 (NIST)

5. Quality assurance

Filtration Group filters and filter elements are produced according to the following international standards:

Norm	Designation
DIN ISO 2 941	Hydraulic fluid power filter elements; verification of collapse/burst resistance
DIN ISO 2 942	Hydraulic fluid power filter elements; verification of fabrication integrity
DIN ISO 2 943	Hydraulic fluid power filter elements; verification of material compatibility with fluids
DIN ISO 3 723	Hydraulic fluid power filter elements; method for end load test
DIN ISO 3 724	Hydraulic fluid power filter elements; verification of flow fatigue characteristics
ISO 3 968	Hydraulic fluid power-filters-evaluation of pressure drop versus flow characteristics
ISO 10 771.1	Fatigue pressure testing of metal containing envelopes in hydraulic fluid applications
ISO 16 889	Hydraulic fluid power filters-multi-passmethod for evaluation filtration performance of a filter element

4. Filter performance data

tested according to ISO 16889 (multipass test)

Sm-x-elements with

max. Δp 10 bar

Sm-x 3 $\beta_{5(C)} \geq 200$

Sm-x 10 $\beta_{10(C)} \geq 200$

Sm-x 25 $\beta_{20(C)} \geq 200$

values guaranteed up to

5 bar differential pressure

6. Symbols

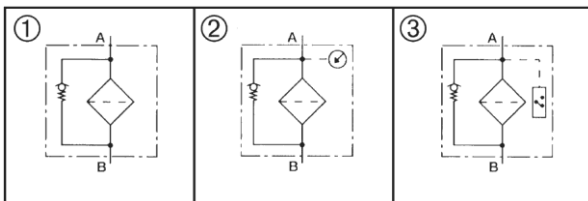

7. Order numbers

Example for ordering filters:

1. Housing design	2. Filter element
Housing NG 35 with hose connection, bypass valve, breather and pressure gauge Type: Pi 53003/1-141	Mic 10 Type: 852 939 Mic 10

7.1 Housing design							
Nominal size NG [l/min]	Type	Version filter head	① with bypass 1.5 bar	with breather	② with bypass and gauge	③ with pressure switch normally closed	③ with pressure switch normally open
35	Pi 53003/1-009	Filter head PA 6 with hose-connection DN20					
	Pi 53003/1-020						
	Pi 53003/1-144						
	Pi 53003/1-145						
	Pi 53003/1-146						
	Pi 53003/1-141						
	Pi 53003/1-142						
	Pi 53003/1-143						
	Pi 53003/2-009	Al-filter head G½					
	Pi 53003/2-020						
50	Pi 53005/1-009	Filter head PA 6 with hose-connection DN20					
	Pi 53005/1-020						
	Pi 53005/1-144						
	Pi 53005/1-145						
	Pi 53005/1-146						
	Pi 53005/1-141						
	Pi 53005/1-142						
	Pi 53005/1-143						
	Pi 53005/2-009	Al-filter head G½					
	Pi 53005/2-020						

7.2 Filter elements*					
Nominal size NG [l/min]	Order number	Type	Filter material	max. Δ p [bar]	Filter surface [cm²]
35	78309387	852 939 Mic 10	Mic 10	5	870
	78206781	852 939 Mic 25	Mic 25		
	79312117	852 588 Sm-x 3	Sm-x 3	10	650
	79312125	852 588 Sm-x 10	Sm-x 10		
	79312133	852 588 Sm-x 25	Sm-x 25		
50	78309395	852 940 Mic 10	Mic 10	5	1100
	79312315	852 940 Mic 25	Mic 25		
	79312158	852 945 Sm-x 3	Sm-x 3	10	810
	79312166	852 945 Sm-x 10	Sm-x 10		
	79312174	852 945 Sm-x 25	Sm-x 25		

* a wider range of element types is available on request

7.3 Breather element (only for filter head PA 6, batch size 3 pcs.)				
Nominal size NG [l/min]	Order number	Type	Filter material	Filter surface [cm ²]
35	78206831	852 937	Mic	40
50				

8. Technical Specifications

Design:	tank mounting filter
Nominal pressure:	6 bar (90 psi)
Test pressure:	9 bar (130 psi)
Temperature range:	-10 °C to +80 °C (other temperature ranges on request)
Bypass setting:	Δp 1.5 bar
Filter head material:	plastic-PA 6/Al
Filter housing material:	plastic PA 6
Filter cover material:	plastic PA 6
Indication range of pressure gauge:	0 to 4 bar
Activating pressure of pressure switch:	1.2 bar
Electrical data of pressure switch:	
Max. voltage:	42 V
Max. current:	2 A
Contact load:	100 VA
Type of protection:	IP 65 - with protection cap
Contact:	normally open/closed
Electrical connection:	AMP 6,3 DIN 46248 connector according to DIN 46247, connection method 2-pole

We draw attention to the fact that all values indicated are average values which do not always occur in specific cases of application. Our products are continually being further developed. Values, dimensions and weights can change as a result of this. Our specialized department will be pleased to offer you advice.

We recommend to contact us concerning applications of our filters in areas governed by the EU Directive 94/9 EC (ATEX 95). The standard version can be used for liquids based on mineral oil (corresponding to the fluids in Group 2 of Directive 97/23 EC Article 9). If you consider to use other fluids please contact us for additional support.

Subject to technical alteration without prior notice.

9. Dimensions

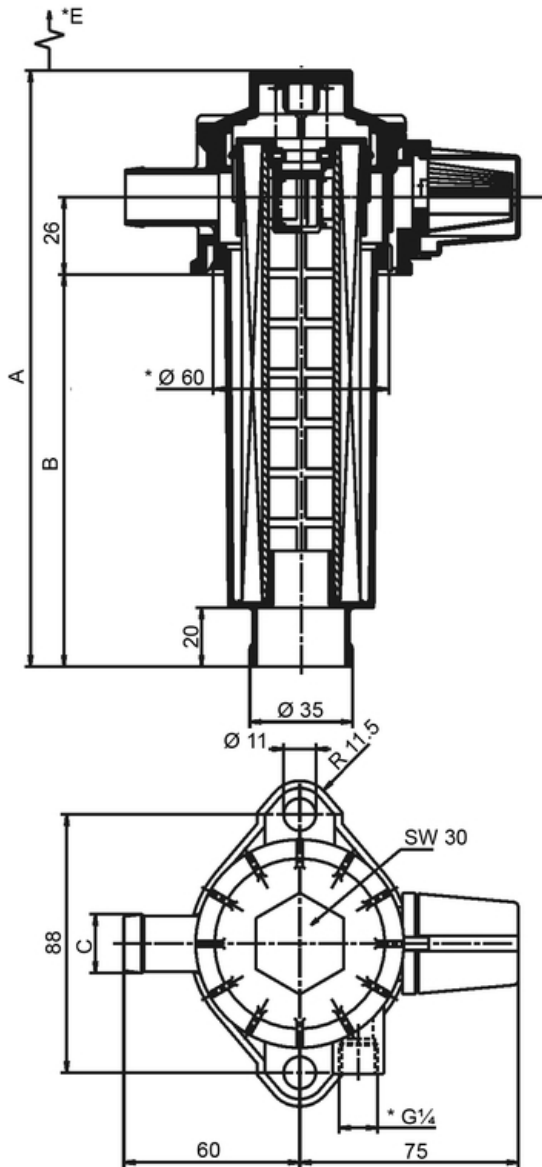

Version with filter head PA 6

*E= Minimum clearance for filter element removal

* Ø 60= Mounting hole Ø 60

*G¼= Option

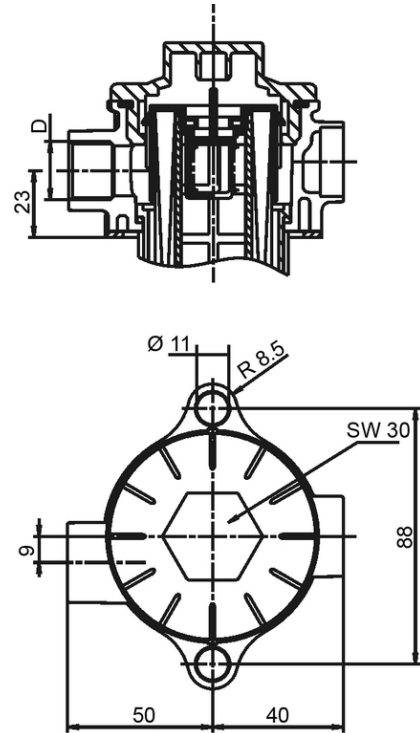

Version with filter head AI

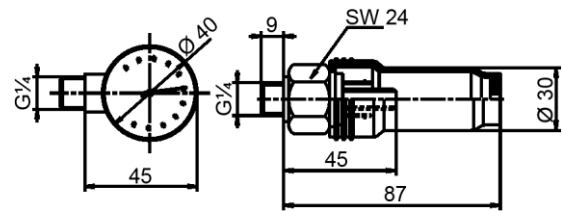

All dimensions except "D" in mm.

Type	A	B	C	D	E
Pi 53003/1	203	133,5	DN20	-	130
Pi 53003/2	203	135,5	-	G½	130
Pi 53005/1	241	171,5	DN20	-	180
Pi 53005/2	241	173,0	-	G½	180

10. Installation, operating and maintenance instructions

10.1 Filter installation

When installing the filter make sure that :

- a) Sufficient space is available to remove filter element and filter housing
 - b) The mounting hole in the tank top is not excessively large, to ensure proper sealing,
 - c) The filter is free of tension after installation, max. torque 7 Nm.
- Preferably the filter should be installed with the filter housing pointing downwards.

10.2 Connecting the electrical pressure switch

The electrical pressure switch is connected via connectors according to DIN 46247.

10.3 When should the filter element be replaced?

1. Filters equipped with pressure gauge:
When the dynamic pressure reaches 1.2 bar (red/green indication), the filter element must be replaced.
2. Filters equipped with pressure switch:
During cold starts, the pressure switch may give a signal. If the electrical signal has not switched off after reaching operating temperature, the filter element must be replaced after the end of the shift.
3. Filters without indicator:
The filter element should be replaced after trial run or flushing of the system.
Afterwards follow instructions of manufacturer.
4. Please, always ensure that you have original Filtration Group spare elements in stock: Disposable elements (Mic, Sm-x) cannot be cleaned.

10.4 Element replacement

1. Stop system and relieve filter from pressure.
2. Unscrew cover, turning counter-clockwise.
3. Remove filter housing and filter element by pulling upwards.
4. Remove filter element with a side-to-side motion.
5. Clean the filter housing with a suitable medium.
6. Check O-rings on filter cover and filter housing for damage. Replace, if necessary.
7. Make sure that the order number on the spare element corresponds to the order number of the filter name-plate.
8. Remove filter element from plastic bag and reassemble in reverse order (items 1 to 4). The cover have to tightened with max. 20 Nm.
9. Contaminated Mic elements can be reduced to ashes. Sm-x filter elements must be disposed in another way.

10.5 Replacement of air breather filter element (plastic filter head only)

1. Push slightly on the lid and air breather element downwards (lid A).
2. Remove lid and element from the lower hook.
3. Pull out element from the lid.
4. Install new element in the lid.
5. Installation in reverse order.
6. Check correct position of the lid.

Note: Filter element and air breather element should be always replaced at the same time.

Subject to technical alteration without prior notice.

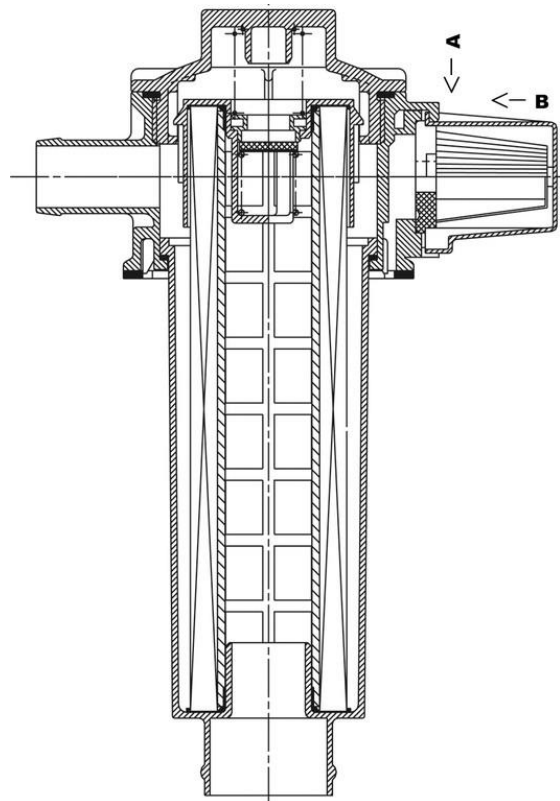

11. Spare parts list

Order numbers for spare parts	
Type	Order number
Seal kit NBR	
Pi 530.../1	78309072
Pi 530.../2	78206062
Pressure gauge	79358326
Pressure switch	
normally closed	77870587
normally open	77863814
Breather element for Pi 530.../1 (batch size 3 pcs.)	78206831