

Valve Extensions

Schrader Pacific valve extensions provide a seal against contaminants while extending the valve mouth for convenient access. Fits standard .305-32" valve cap threads. Maximum operating pressure, 150 psi.

Due to the variety of operating conditions and applications, the customer is responsible to perform their own testing to ensure performance, safety and warranty requirements for the intended application.

WARNING: *These products can expose you to chemicals, including lead which is known to the State of California to cause cancer or birth defects or other reproductive harm.*

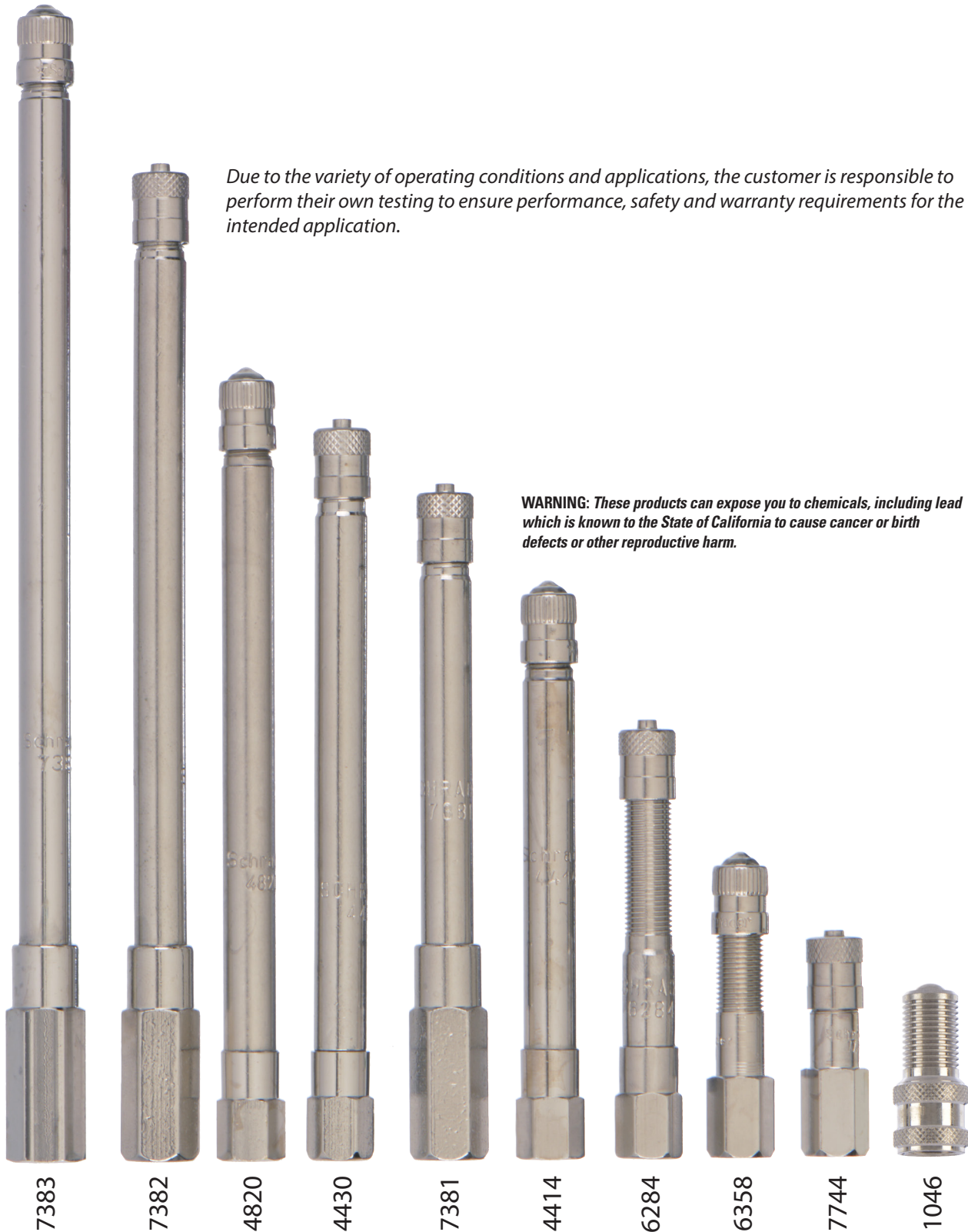

Valve Extensions

Straight Rigid Extensions

These extensions simplify air service where wheel, rim, brake, etc. hamper access to the tire valve. Valve mouth is extended to desired position for inflating, gauging and deflating. An extension core (a special plunger pin) contacts the core in the tire valve. The extension fits regular cap threads (.305" -32) at valve mouth. A washer acts as a seal between valve mouth and extension. Maximum operating pressure, 150 psi.

Type One

Part Number	Reference Number	A in (mm)	A1 in (mm)	J in (mm)	Hex Size in (mm)	Extension Core	Valve Cap
077447099	7744	1.00 (25.4)	1.25 (31.75)	.38 (9.5)	.38 (9.5)	7744-196	7572
063587095	6358	1.41 (35.7)	1.69 (40.8)	.81 (20.6)	.38 Flats (9.5)	6358-4	7572
134300	6284	2.22 (56.4)	2.50 (63.5)	1.25 (31.8)	.38 Flats (9.5)	6284-4	7572
044147075	4414	3.11 (79.0)	3.39 (86.1)	.38 (9.5)	.38 Flats (9.5)	4414-6	7572
044307119	4430	4.11 (104.4)	4.39 (111.5)	.38 (9.5)	.38 Flats (9.5)	4430-4	7572
048200507	4820	4.44 (112.7)	4.72 (119.9)	.38 (9.5)	.38 Flats (9.5)	4820-4	7572

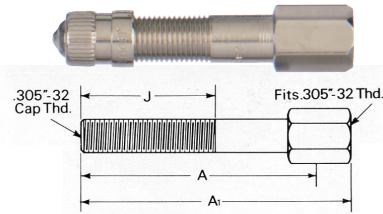

Type Two

Part Number	Reference Number	A in (mm)	A1 in (mm)	J in (mm)	Extension Core	Valve Cap
073817129	7381	3.06 (77.8)	4.00 (101.6)	.38 (9.5)	7381-4	7572
073827119	7382	5.06 (128.6)	6.00 (152.4)	.38 (9.5)	7382-4	7572
373837129	7383	6.06 (154.0)	7.00 (177.8)	.38 (9.5)	7383-4	7572

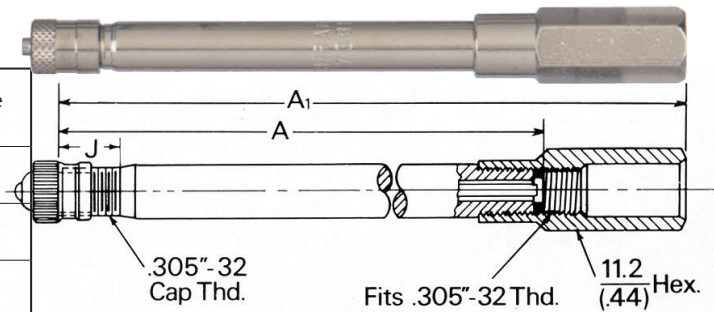

Truck and Bus Extensions

Part Number	Schrader Number	Effective in (mm)
010460250	1046	.75 (19.1)

These double sealing extensions eliminate the need for valve caps on truck valve stems, effectively reducing tire service time in fleet operations.

WARNING: These products can expose you to chemicals, including lead which is known to the State of California to cause cancer or birth defects or other reproductive harm.

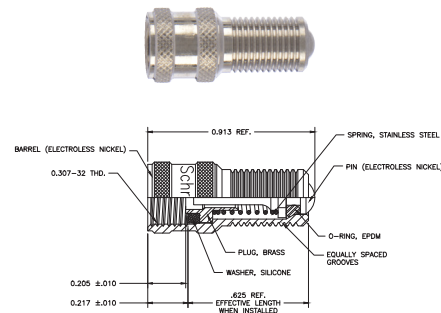

Due to the variety of operating conditions and applications, the customer is responsible to perform their own testing to ensure performance, safety and warranty requirements for the intended application.

