

Temperature switches TS/TÖ-ATEX

Temperature sensors TF-ATEX



Installation and Operation Instructions

Original instructions





Bühler Technologies GmbH, Harkortstr. 29, D-40880 Ratingen
Tel. +49 (0) 21 02 / 49 89-0, Fax: +49 (0) 21 02 / 49 89-20
Internet: www.buehler-technologies.com
E-Mail: fluidcontrol@buehler-technologies.com

Read this instruction carefully prior to installation and/or use. Pay attention particularly to all advises and safety instructions to prevent injuries. Bühler Technologies can not be held responsible for misusing the product or unreliable function due to unauthorised modifications.

All rights reserved. Bühler Technologies GmbH 2021

Document information

Document No..... BE140010
Version..... 06/2021
Part No..... 9031272

Contents

1	Introduction.....	2
1.1	Intended Use.....	2
1.2	Layout and Functionality.....	2
1.2.1	Layout TF-M-Pt100/TF-E-Pt100 temperature sensor.....	2
1.2.2	Layout TSM/TSE/TSK/TSA/TÖA temperature switch.....	2
1.3	Scope of Delivery.....	2
1.4	Type plate.....	2
1.5	Model key for TF temperature sensor.....	3
1.6	Model key for TSK temperature switch.....	3
1.7	Model key for TSM/TSE temperature switches.....	3
1.8	TSA/TÖA Ordering instructions.....	4
2	Safety instructions.....	5
2.1	Important advice.....	5
2.2	General hazard warnings.....	6
3	Transport and storage.....	7
4	Installation and connection.....	8
4.1	Installation.....	8
4.2	Electrical connections.....	8
4.2.1	PA connection (potential equalisation).....	8
4.2.2	Intrinsically-safe connection.....	9
5	Operation and control.....	10
6	Cleaning and Maintenance.....	11
7	Service and repair.....	12
8	Disposal.....	13
9	Appendices.....	14
9.1	Materials temperature switches/sensors – ATEX.....	14
9.2	Bill of materials (parts in contact with mediums).....	14
9.3	Technical Data TSA-Atex/TÖA-Atex.....	15
9.4	Technical Data TSK-Atex.....	16
9.5	Technical Data TSM-Atex/TSE-Atex.....	17
9.6	Technical Data TF-M-Atex/TF-E-Atex.....	18
9.7	Pin assignments.....	19
10	Attached documents.....	20

1 Introduction

1.1 Intended Use

The temperature switch/sensor is used to monitor temperatures inside a tank. The TSA and TÖA temperature switches can also be used in tube systems and cooling matrices. In this case the tube is located inside the tank.

According to EN 60079-11, TS/TÖ or TF series temperature switches/sensors are simple electrical apparatuses without separate voltage source intended for tank top installation.

When used in explosive areas this type may only be operated on intrinsically-safe circuits. When using intrinsically-safe connections they can be installed in Zone 1 (Ex group IIC) explosive areas and the temperature level be monitored in a Zone 0 environment. The intrinsically-safe power supply must be suitable for the respective zone. The limits inside these operating instructions must be observed.

The temperature switches/sensors must not be used in highly flammable or corrosive liquids.

Before installing the temperature switch/sensor, verify the listed technical data meet the application parameters. Also observe the applicable requirements of EN 60079-14.

Further check if all contents are complete.

Please note the specific values of the temperature switches/levels when connecting and the correct version when ordering spare parts.

1.2 Layout and Functionality

1.2.1 Layout TF-M-Pt100/TF-E-Pt100 temperature sensor

Type TF temperature sensors use a Pt100 temperature sensor to generate a temperature-dependent resistance signal. The Pt100 sensor is installed at the lowest point of the sensor tube to always ensure sufficient contact with the medium being measured.

1.2.2 Layout TSM/TSE/TSK/TSA/TÖA temperature switch

TS switches use a bi-metal switch to signal a set temperature value. Unlike the TSM standard version, the TSK and TSA/TÖA versions feature bi-metal switches with a lower hysteresis. The TSA/TÖA version is further specifically designed for installation in tube systems and cooling matrices. The bi-metal switch is installed at the lowest point of the sensor tube to always ensure sufficient contact with the medium being measured.

1.3 Scope of Delivery

- Temperature switch/sensor
- Elastic profile gasket G1/2 (NBR): 11 20 101
- Elastic profile gasket G3/4 (NBR): 11 20 102
- Product Documentation

1.4 Type plate

Example:

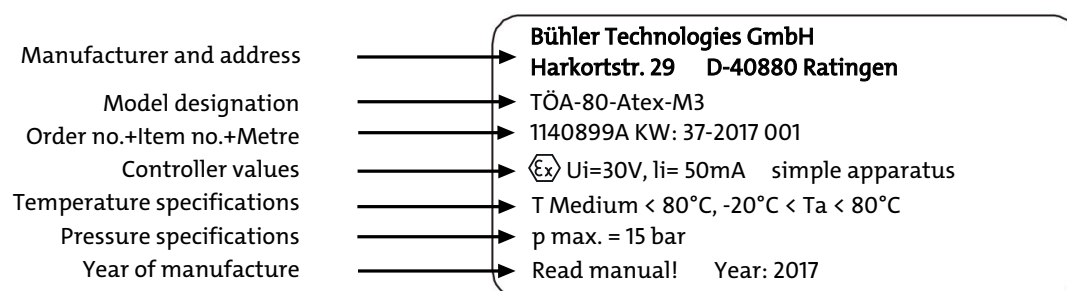

1.5 Model key for TF temperature sensor

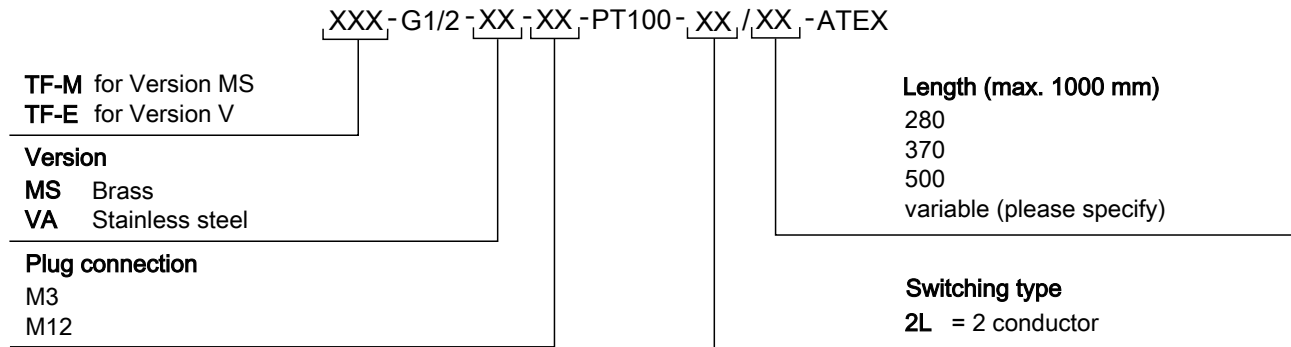

1.6 Model key for TSK temperature switch

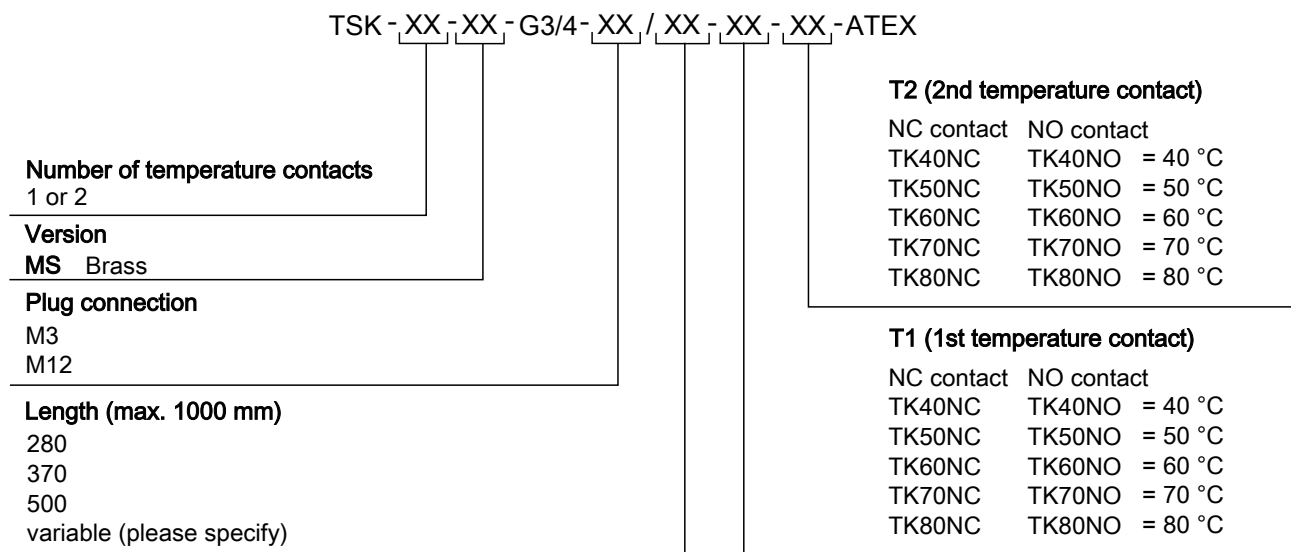

1.7 Model key for TSM/TSE temperature switches

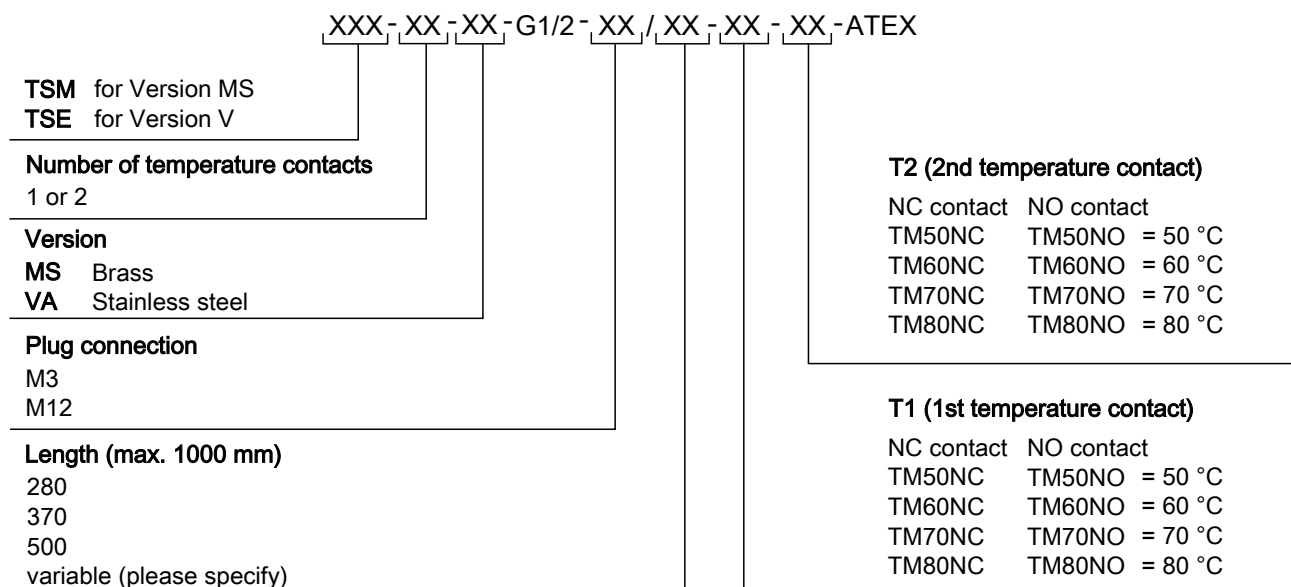

1.8 TSA/TÖA Ordering instructions

Description	Item no.	Plug connection
TSA-25-Atex	1139699A	M3
TSA-40-Atex	1139599A	M3
TSA-50-Atex	1138599A	M3
TSA-60-Atex	1138699A	M3
TSA-70-Atex	1138799A	M3
TSA-80-Atex	1139299A	M3
TÖA-25-Atex	1142899A	M3
TÖA-40-Atex	1143299A	M3
TÖA-50-Atex	1142199A	M3
TÖA-60-Atex	1143399A	M3
TÖA-70-Atex	1140299A	M3
TÖA-80-Atex	1140899A	M3

2 Safety instructions

2.1 Important advice

This unit may only be used if:

- The product is being used under the conditions described in the operating- and system instructions, used according to the nameplate and for applications for which it is intended. Any unauthorized modifications of the device will void the warranty provided by Bühler Technologies GmbH,
- The specifications and markings in the type plate are observed,
- The specified limits are observed,
- The equipment is operated on intrinsically-safe circuits, see chapter “Intrinsically-Safe Connection”,
- The protective element is installed outside the explosive area,
- No equipment functions exceed the limits,
- Monitoring equipment / protection devices are connected correctly,
- Service and repair work not described in these instructions are performed by Bühler Technologies GmbH,
- Genuine replacement parts are used.

Regulations EN 60079-14 and EN 60079-17 must be observed when erecting electrical systems in explosive areas.

Additional national regulations pertaining to initial operation, operation, maintenance, repairs and disposal must be observed.

These operating instructions are a part of the equipment. The manufacturer reserves the right to change performance-, specification- or technical data without prior notice. Please keep these instructions for future reference.

Signal words for warnings

DANGER	Signal word for an imminent danger with high risk, resulting in severe injuries or death if not avoided.
WARNING	Signal word for a hazardous situation with medium risk, possibly resulting in severe injuries or death if not avoided.
CAUTION	Signal word for a hazardous situation with low risk, resulting in damaged to the device or the property or minor or medium injuries if not avoided.
NOTICE	Signal word for important information to the product.

Warning signs

These instructions use the following warning signs:

	Warns of a general hazard		General information
	Warns of voltage		Unplug from mains
	Warns not to inhale toxic gasses		Wear respiratory equipment
	Warns of corrosive liquids		Wear a safety mask
	Warns of explosive areas		Wear gloves

2.2 General hazard warnings

The equipment must be installed by a professional familiar with the safety requirements and risks.

Be sure to observe the safety regulations and generally applicable rules of technology relevant for the installation site. Prevent malfunctions and avoid personal injuries and property damage.

The operator of the system must ensure:

- Safety notices and operating instructions are available and observed,
- The respective national accident prevention regulations are observed,
- The permissible data and operational conditions are maintained,
- Safety guards are used and mandatory maintenance is performed,
- Legal regulations are observed during disposal,
- compliance with national installation regulations.

Maintenance, Repair

Please note during maintenance and repairs:

- Repairs to the unit must be performed by Bühler authorised personnel.
- Only perform conversion-, maintenance or installation work described in these operating and installation instructions.
- Always use genuine spare parts.
- Do not install damaged or defective spare part. If necessary, visually inspect prior to installation to determine any obvious damage to the spare parts.

Always observe the applicable safety and operating regulations in the respective country of use when performing any type of maintenance.

The method for cleaning the devices must be adapted to the IP protection class of the devices. Do not use cleaners which could damage the device materials.

DANGER

Toxic, acidic gases/liquids

Protect yourself from toxic, corrosive gasses/liquids when performing any type of work.
Wear appropriate protective equipment.



3 Transport and storage

Only transport the product inside the original packaging or a suitable alternative.

The equipment must be protected from moisture and heat when not in use. It must be stored in a covered, dry, dust-free room at room temperature.

4 Installation and connection

4.1 Installation

The temperature switch/sensor comes fully assembled and can be mounted to the tank by screw-in thread and seal. Please be sure to leave enough space between the tank wall and add-ons.

The maximum torque of the screw-in thread is 25 Nm. When installing, be sure the sealing face is clean and even. Always be sure to screw the temperature sensor/switch into the fitting thread. Sealed with an elastic sealing ring. No other sealants required.

4.2 Electrical connections

4.2.1 PA connection (potential equalisation)

CAUTION

Electrostatic charge



The housings of the temperature switches/sensors must be connected to the tank via external PA connection!

Ensure the temperature switches/sensors are adequately earthed (minimum conductor cross-section 4 mm²).

Particularly also observe the requirements of EN 60079-14.



Depending on the version the temperature switches/sensors have an external PA connection. This is identified by the decal shown on the left. The connection uses an M4 thread. The PA cable for potential equalisation between the temperature switch/sensor and the tank is not included with this version and must be supplied and installed by the customer.

Layout of the PA connection:

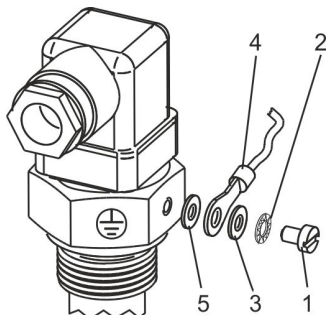

1 Screw	4 PA cable (to be installed by the customer)
2 Serrated washer	5 Washer
3 Washer	

PA connection example:

Drawing A

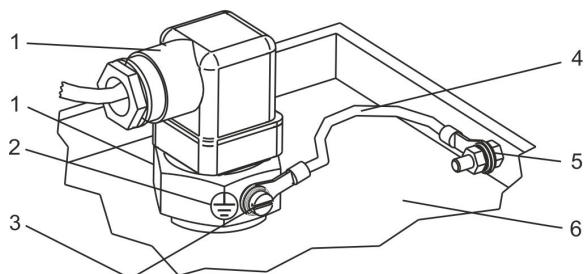

1 Temperature switch TSK-Atex	5 PA cable
2 PA decal	6 PA connection on the tank
3 PA connection on the temperature switch	7 Tank

4.2.2 Intrinsically-safe connection

CAUTION



Explosion hazard due to prohibited electrical connection data

Prohibited electrical connection data can cause an explosive gas mixture to ignite. In areas with explosive gas atmospheres the temperature switches/sensors may only be operated with an intrinsically-safe power supply. The power supply must be suitable for the respective zone. The limits specified in these operating instructions must be observed and must not be exceeded, even with two separate intrinsically-safe power supplies. Ensure the limits will not be exceeded, even in the event of a fault, e.g. accidental series or parallel connection.

Please observe the relevant safety requirements, e.g. EN 60079-11 and EN 60079-14, when installing and operating intrinsically-safe equipment.

According to EN 60079-11 the components for level and temperature monitoring are simple electrical equipment and to be considered purely ohmic circuits. They may only be operated with a type-tested controller with an intrinsically-safe circuit.

Please refer to chapter "Technical Data" for the pin assignment and technical data. Please refer to the chart below for the technical parameters and the approved limits (U_i , I_i , C_i , L_i , and P_i) for intrinsically-safe operation:

	U_i	I_i	C_i	L_i	P_i
Temperature contact	30 V	50 mA	negligible	negligible	100 mW
Temperature sensor	30 V	50 mA	negligible	negligible	100 mW
Pt100 temperature sensor	30 V	50 mA	negligible	negligible	100 mW

Remarks about the Pt100 connection

Operate the Pt100 with the respective EX approved RTD converter or a separating barrier with RTD input, suitable for EX. The measuring current I_c must be $\leq 1 \text{ mA}$ to prevent excessive self-heating, which will cause measuring errors.

5 Operation and control

DANGER

Toxic, acidic gases/liquids

Protect yourself from toxic, corrosive gasses/liquids when performing any type of work. Wear appropriate protective equipment.



DANGER

Dangerous electrostatic charge (explosion hazard)

The equipment may only be used where normal operating conditions do not produce frequent flammable, electrostatic discharge.



Sparking

Incendive electrostatic charges may occur when cleaning plastic housing parts and decals (e.g. with a dry cloth or compressed air). The sparks this produces could ignite flammable, explosive atmospheres.

Always clean plastic housing parts and decals **with a damp cloth!**

DANGER

Impact

Strong blows to the housing can produce sparks, which can ignite an EX atmosphere. Protect the equipment from external impact. Damaged housing parts must be replaced immediately.



CAUTION

Explosion hazard due to prohibited electrical connection data

Prohibited electrical connection data can cause an explosive gas mixture to ignite. In areas with explosive gas atmospheres the temperature switches/sensors may only be operated with an intrinsically-safe power supply. The power supply must be suitable for the respective zone. The limits specified in these operating instructions must be observed and must not be exceeded.

Please observe the relevant safety requirements, e.g. EN 60079-11 and EN 60079-14, when installing and operating intrinsically-safe equipment.



NOTICE

The device must not be operated beyond its specifications.



Before startup, check

- The electrical connections are undamaged and correctly installed,
- The temperature switch/sensor is connected intrinsically-safe (proof of intrinsic safety e.g. according to EN 60079-14),
- No parts have been removed from the temperature switch/sensor,
- Protection and monitoring devices are installed and functional (e.g. switch amplifier),
- The ambient parameters and technical specifications (e.g. U_p , I_i) are met,
- Electrical connections are securely connected and the monitoring devices are connected and set as prescribed,
- Precautions have been taken,
- the connectors are closed and the cable glands are properly sealed,
- The requirements of EN 60079-14 are met,
- The earth is proper and functional.

6 Cleaning and Maintenance

This device is maintenance-free.

The method for cleaning the devices must be adapted to the IP protection class of the devices. Do not use cleaners which could damage the device materials.

7 Service and repair

This chapter contains information on troubleshooting and correction should an error occur during operation.

Repairs to the unit must be performed by Bühler authorised personnel.

Please contact our Service Department with any questions:

Tel.: +49-(0)2102-498955 or your agent

If the equipment is not functioning properly after correcting any malfunctions and switching on the power, it must be inspected by the manufacturer. Please send the equipment inside suitable packaging to:

Bühler Technologies GmbH

- Reparatur/Service -

Harkortstraße 29

40880 Ratingen

Germany

Please also attach the completed and signed RMA decontamination statement to the packaging. We will otherwise be unable to process your repair order.

You will find the form in the appendix of these instructions, or simply request it by e-mail:

service@buehler-technologies.com.

8 Disposal

Dispose of parts so as not to endanger the health or environment. Follow the laws in the country of use for disposing of electronic components and devices during disposal.

9 Appendices

9.1 Materials temperature switches/sensors – ATEX

Version	Screw-in unit, tube and plug	Seals
TF-M-Atex-...	Brass	NBR/FKM
TF-E-Atex-...	Stainless steel	NBR
TSM-1(2)-Atex-...	Brass	NBR/FKM
TSE-1(2)-Atex-...	Stainless steel	NBR
TSK-1(2)-Atex-...	Brass	NBR/FKM
TSA-...-Atex	Anodised aluminium	NBR
TÖA-...-Atex	Anodised aluminium	NBR

9.2 Bill of materials (parts in contact with mediums)

Screw-in unit:	Stainless steel, brass or anodised aluminium (varies by version)
Switching tube and plug:	Stainless steel, brass or anodised aluminium (varies by version)
Seal:	NBR

The operator must ensure the materials of the temperature switch/sensor in contact with mediums offer sufficient chemical resistance against the fluid being monitored!

9.3 Technical Data TSA-Atex/TÖA-Atex

TSA-Atex, TÖA-Atex

Switch element:	bi-metal
Switching function:	NO contact (NO)
Switching temperature:	25 to 80 °C
Probe length:	29 mm
Probe material:	Anodised aluminium
Max. operating pressure:	15 bars
Operating temperature:	max. +80 °C
Ambient temperature:	-20 to +80 °C

Temperature contacts

Tolerance:	± 5 K		
Switch-back difference:	15 K ± 3 K		
Switching point:		NO*	NC*
	25 °C	TSA-25	TÖA-25
	40 °C	TSA-40	TÖA-40
	50 °C	TSA-50	TÖA-50
	60 °C	TSA-60	TÖA-60
	70 °C	TSA-70	TÖA-70
	80 °C	TSA-80	TÖA-80

Other temperatures available upon request

*NC = NC contact/NO = NO contact All data for rising temperature

Accessories

Connection cable M12x1 (5-pin) 3.0 m long, item no.: 9144050018

Switch amplifier for temperature switches see data sheet no. 18 0003

The device is suitable for use in ATEX category II 2 G Ex ìb IIC T4.

The temperature switch may only be operated on intrinsically-safe circuits!

Dimensions

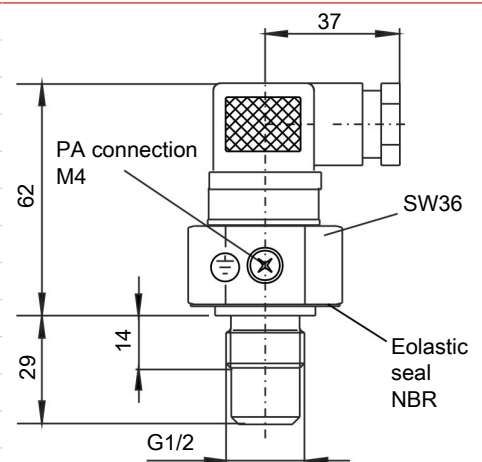

Temperature contacts

P_i	100 mW
U_i	30 V
I_i	50 mA
$L_i; C_i$	Negligible

Plug connection

M3

Dimensions:

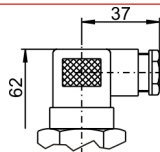

Number of pins:	3-pin + PE
DIN EN:	175301-803
Protection class:	IP65
Cable fitting:	PG 11

Other plug connections available upon request

9.4 Technical Data TSK-Atex

TSK-Atex

Versions:	TSK-1 = with one temperature contact TSK-2 = with two temperature contacts
Switch element:	bi-metal
Switching function:	NC = NC contact/NO = NO contact
Switching temperature:	45 to 80 °C (also see chart)
Probe length L max.:	1000 mm
Probe material:	Brass
Max. operating pressure:	1 bar
Operating temperature:	max. +80 °C
Ambient temperature:	-20 to +80 °C

Temperature contacts

Switch-back difference:	10 K ± 5 K	
Switching point:	NC*	NO*
	45 °C	TKÖ-45
	55 °C	TKÖ-55
	65 °C	TKÖ-65
	75 °C	TKÖ-75

Other temperatures available upon request

*NC = NC contact/NO = NO contact All data for rising temperature

Accessories

Connection cable M12x1 (5-pin) 3.0 m long, item no.: 9144050018

Switch amplifier for temperature switches see data sheet no. 18 0003

The device is suitable for use in ATEX category II 2 G Ex ib IIC T4.

The temperature switch may only be operated on intrinsically-safe circuits!

Dimensions

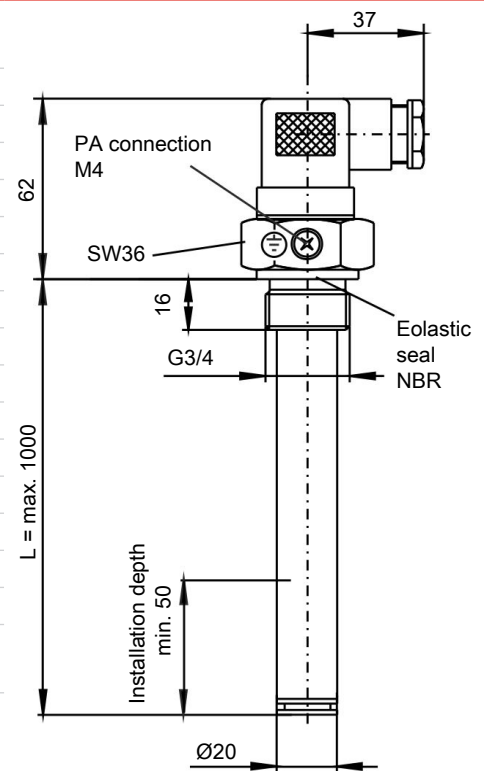

Temperature contacts

P_i	100 mW
U_i	30 V
I_i	50 mA
$L_i; C_i$	Negligible

Connector

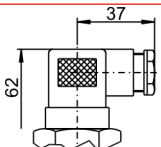
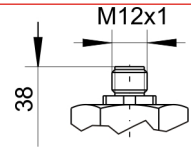
	M3	M12 (base)
Dimensions:		
Number of pins:	3-pin + PE	4-pin+PE
DIN EN:	175301-803	
IP rating:	IP65	IP 67**
Cable fitting:	PG 11	PG 7**

**with IP67 cable box screwed on

Other connectors available on request

9.5 Technical Data TSM-Atex/TSE-Atex

TSM-Atex, TSE-Atex

Versions:	TSM-1/TSE-1 = with one temperature contact TSM-2/TSE-2 = with two temperature contacts
Switch element:	bi-metal
Switching function:	NC = NC contact/NO = NO contact
Switching temperature:	50 to 80 °C (also see chart)
Probe length L max.:	1000 mm

	TSM	TSE
Probe material:	Brass	1.4571
Max. operating pressure:	5 bar	10 bar
Operating temperature:	max. +80 °C	
Ambient temperature:	-20 to +80 °C	

Temperature contacts

Switch-back difference for TMÖ-50 to TMÖ-80:	18 K ± 5 K	
Switch-back difference for TSM-60:	53 K ± 5 K	
Switch-back difference for TSM-70:	40 K ± 5 K	
Switching point:	NC*	NO*
50 °C	TMÖ-50	-
60 °C	TMÖ-60	TSM-60
70 °C	TMÖ-70	TSM-70
80 °C	TMÖ-80	-

Other temperatures available upon request

*NC = NC contact/NO = NO contact All data for rising temperature

Accessories

Connection cable M12x1 (5-pin) 3.0 m long, item no.: 9144050018

Switch amplifier for temperature switches see data sheet no. 18 0003

The device is suitable for use in ATEX category II 2 G Ex ib IIC T4.

The temperature switch may only be operated on intrinsically-safe circuits!

Dimensions

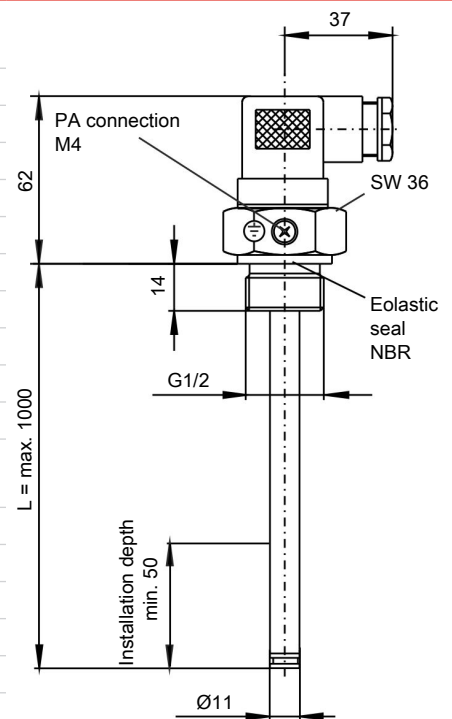

Temperature contacts

P_i	100 mW
U_i	30 V
I_i	50 mA
$L_i; C_i$	Negligible

Connector

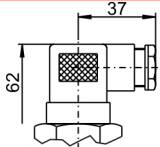
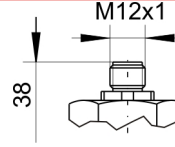
	M3	M12 (base)
Dimensions:		
Number of pins:	3-pin + PE	4-pin+PE
DIN EN:	175301-803	
IP rating:	IP65	IP 67**
Cable fitting:	PG 11	PG 7**

**with IP67 cable box screwed on

Other connectors available on request

9.6 Technical Data TF-M-Atex/TF-E-Atex

TF-M-Atex, TF-E-Atex

Operating temperature:	max. +80 °C	
Ambient temperature:	-20 to +80 °C	
	TF-M-Atex-Pt100	TF-E-Atex-Pt100
Probe material:	Brass	1.4571
Max. operating pressure:	5 bar	10 bar
Probe length L max.:	1000 mm	1000 mm

Pt100 resistance thermometer

Tolerance:	± 0.8 K
Measuring current I_c :	≤ 1 mA
P_i :	100 mW
I_i :	50 mA
U_i :	30 V
L_i, C_i :	negligible

Accessories

Connection cable M12x1 (5-pin) 3.0 m long, item no.: 9144050018
 Switch amplifier for temperature sensors see data sheet no. 18 0003

The device is suitable for use in ATEX category II 2 G Ex ib IIC T4.

The temperature sensors may only be operated on intrinsically-safe circuits!

Dimensions

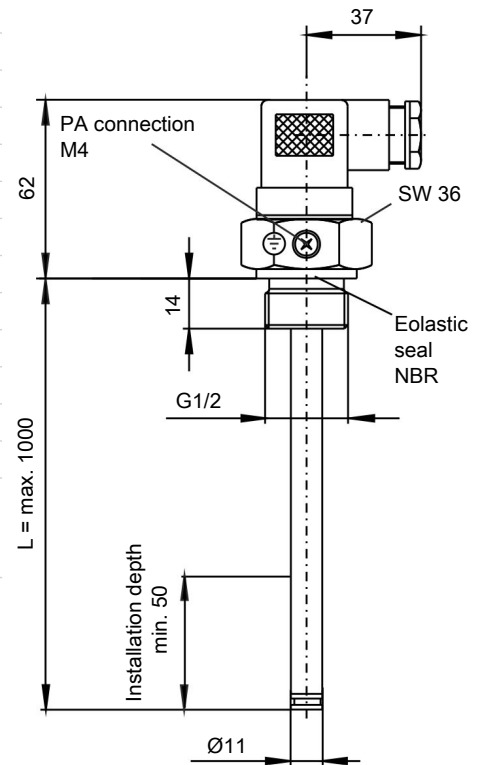

Pt100 measuring resistance base values

°C	0	10	20	30	40	50	60	70	80	90	100
Ohm	100.00	103.90	107.79	111.67	115.54	119.40	123.24	127.07	130.89	134.70	138.50

Connector

Dimensions:

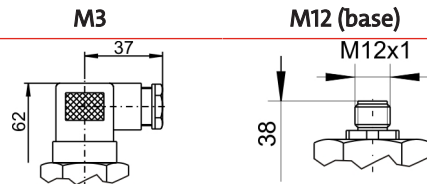

Number of pins:	3-pin + PE	4-pin+PE
DIN EN:	175301-803	
IP rating:	IP65	IP 67**
Cable fitting:	PG 11	PG 7**

**with IP67 cable box screwed on

Other connectors available on request

9.7 Pin assignments

Note: On special models the pin assignments may vary from the following connection schematics. In this case, please refer to the pin assignments included with the respective probe models.

Temperature sensor TF-M-Pt100/TF-E-Pt100

with M3 plug as per EN 1756301-803

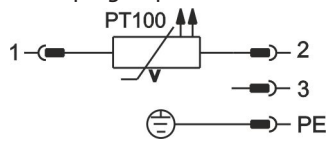

with M12 plug

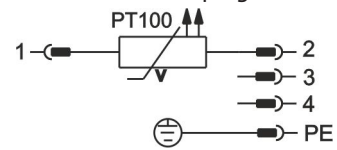

Bi-metal temperature switch TSM/TSE/TSK/TSA/TÖA:

1 temperature contact

with M3 plug as per EN 1756301-803

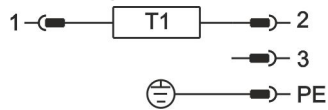

with M12 plug

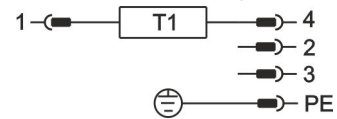

Bi-metal temperature switch TSM/TSE/TSK/TSA:

2 temperature contacts

with M3 plug as per EN 1756301-803

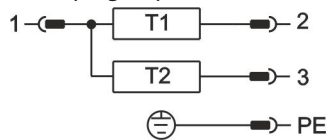

with M12 plug

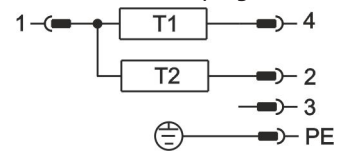

Note!

T1 indicates the temperature contact with the lower switching temperature.

T2 indicates the temperature contact with the higher switching temperature.

10 Attached documents

- Manufacturer Declaration HX100003
- RMA - Decontamination Statement

Herstellererklärung Manufacturer Declaration



der Firma Bühler Technologies GmbH nach
EN 60079-11 Abschn. 5.7 „Einfache elektrische
Betriebsmittel“.

by Bühler Technologies GmbH pursuant to
EN 60079-11 Section 5.7 "Simple apparatus".

Produkt / products: Temperaturschalter (Fühler) / *temperature switches (sensor)*
Typ / type: TS/TÖ...-ATEX; TF...ATEX

Zusätzliche Angaben/additional details:

Die Erklärung gilt für alle Exemplare, die nach den beim Hersteller hinterlegten Fertigungsunterlagen – die Bestandteil dieser Erklärung sind - hergestellt wurden.

Bei den Temperaturfühler TF...-ATEX und Temperaturschaltern TS/TÖ... -ATEX handelt es sich nach EN 60079-11 um einfache elektrische Betriebsmittel ohne eigene Zündquelle, welche für den Tankeinbau oder (ausschließlich bei Typ TSA/TÖA) für den Einbau in Rohrleitungssysteme und Kühlregister bestimmt sind. Gemäß den Anforderungen dieser Norm wird dieses Betriebsmittel keiner Typprüfung und keiner Kennzeichnung nach Richtlinie **2014/34/EU (Atex)** unterworfen.

Bei eigensicherem Anschluss können sie im explosionsgefährdeten Bereich der Zonen 1 (Gruppe IIC) installiert werden. Eine vergleichbare ATEX-Kennzeichnung lautet: II 2G Ex ib IIC T4.

Die Betriebsmittel dürfen nur durch Fachpersonal installiert werden; die einschlägigen Sicherheitsvorschriften (z.B. EN 60079-14) sind zwingend zu beachten.

This declaration is valid for all devices manufactured according to the design and manufacturing specifications of the manufacturer. These specifications are part of this declaration.

*Temperature sensors TF...-ATEX and temperature switches TS/TÖ...-ATEX are simple apparatuses according to EN 60079-11 made for tank top mounting or (only Type TSA/TÖA) installation in tube systems and cooling matrices. In accordance with the requirements of this standard, this equipment is not subject to type approval or marking pursuant to directive **2014/34/EU (Atex)**.*

In case of intrinsically safe connection they can be used in Zone 1 (group IIC) of Ex-areas. A comparable ATEX marking is: II 2 G ex ib IIC T4.

The equipment has to be installed by trained personnel. All safety regulations have to be fulfilled (e.g. EN 60079-14).

Beschaltungswerte der einfachen elektrischen Betriebsmittel/Parameters of the simple apparatuses:

$U_i = 30 \text{ V}$

$I_i = 50 \text{ mA}$

C_i, L_i vernachlässigbar/negligible

Messtrom/Measuring current (Pt100) $\leq 1 \text{ mA}$

Zur Beurteilung der Konformität gemäß Atex-Richtlinie wurden folgende harmonisierte Normen herangezogen:
For the assessment of conformity according to the Atex directive the following standards have been used:

EN 60079-11:2012

EN 60079-0:2012 + A11:2013

Die alleinige Verantwortung für die Ausstellung dieser Konformitätserklärung trägt der Hersteller.
This declaration of conformity is issued under the sole responsibility of the manufacturer.

Dokumentationsverantwortlicher für diese Konformitätserklärung ist Herr Stefan Eschweiler mit Anschrift am Firmensitz.

The person authorised to compile the technical file is Mr. Stefan Eschweiler located at the company's address.

Ratingen, den 20.11.2017

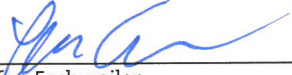
Stefan Eschweiler
Geschäftsführer – Managing Director

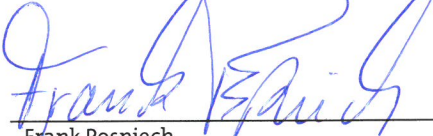
Frank Pospiech
Geschäftsführer – Managing Director

RMA-Formular und Erklärung über Dekontaminierung

RMA-Form and explanation for decontamination



RMA-Nr./ RMA-No.

Die RMA-Nummer bekommen Sie von Ihrem Ansprechpartner im Vertrieb oder Service./ You may obtain the RMA number from your sales or service representative.

Zu diesem Rücksendeschein gehört eine Dekontaminierungserklärung. Die gesetzlichen Vorschriften schreiben vor, dass Sie uns diese Dekontaminierungserklärung ausgefüllt und unterschrieben zurücksenden müssen. Bitte füllen Sie auch diese im Sinne der Gesundheit unserer Mitarbeiter vollständig aus./ This return form includes a decontamination statement. The law requires you to submit this completed and signed decontamination statement to us. Please complete the entire form, also in the interest of our employee health.

Firma/ Company

Firma/ Company
Straße/ Street
PLZ, Ort/ Zip, City
Land/ Country

Ansprechpartner/ Person in charge

Name/ Name
Abt./ Dept.
Tel./ Phone
E-Mail
Serien-Nr./ Serial No.
Artikel-Nr./ Item No.

Gerät/ Device
Anzahl/ Quantity
Auftragsnr./ Order No.

Grund der Rücksendung/ Reason for return

- Kalibrierung/ Calibration Modifikation/ Modification
 Reklamation/ Claim Reparatur/ Repair
 andere/ other

bitte spezifizieren/ please specify

Ist das Gerät möglicherweise kontaminiert?/ Could the equipment be contaminated?

- Nein, da das Gerät nicht mit gesundheitsgefährdenden Stoffen betrieben wurde./ No, because the device was not operated with hazardous substances.
 Nein, da das Gerät ordnungsgemäß gereinigt und dekontaminiert wurde./ No, because the device has been properly cleaned and decontaminated.
 Ja, kontaminiert mit:/ Yes, contaminated with:



explosiv/
explosive



entzündlich/
flammable



brandfördernd/
oxidizing



komprimierte
Gase/
compressed
gases



ätzend/
caustic



giftig,
Lebensgefahr/
poisonous, risk
of death



gesundheitsge-
fährdend/
harmful to
health



gesund-
heitsgefährlich/
health hazard



umweltge-
fährdend/
environmental
hazard

Bitte Sicherheitsdatenblatt beilegen!/ Please enclose safety data sheet!

Das Gerät wurde gespült mit:/ The equipment was purged with:

Diese Erklärung wurde korrekt und vollständig ausgefüllt und von einer dazu befugten Person unterschrieben. Der Versand der (dekontaminierten) Geräte und Komponenten erfolgt gemäß den gesetzlichen Bestimmungen.

This declaration has been filled out correctly and completely, and signed by an authorized person. The dispatch of the (decontaminated) devices and components takes place according to the legal regulations.

Falls die Ware nicht gereinigt, also kontaminiert bei uns eintrifft, muss die Firma Bühler sich vorbehalten, diese durch einen externen Dienstleister reinigen zu lassen und Ihnen dies in Rechnung zu stellen.

Should the goods not arrive clean, but contaminated, Bühler reserves the right, to commission an external service provider to clean the goods and invoice it to your account.

Firmenstempel/ Company Sign

Datum/ Date

rechtsverbindliche Unterschrift/ Legally binding signature



Die Analyse defekter Baugruppen ist ein wesentlicher Bestandteil der Qualitätssicherung der Firma Bühler Technologies.

Um eine aussagekräftige Analyse zu gewährleisten muss die Ware möglichst unverändert untersucht werden. Es dürfen keine Veränderungen oder weitere Beschädigungen auftreten, die Ursachen verdecken oder eine Analyse unmöglich machen.

Bei elektronischen Baugruppen kann es sich um elektrostatisch sensible Baugruppen handeln. Es ist darauf zu achten, diese Baugruppen ESD-gerecht zu behandeln. Nach Möglichkeit sollten die Baugruppen an einem ESD-gerechten Arbeitsplatz getauscht werden. Ist dies nicht möglich sollten ESD-gerechte Maßnahmen beim Austausch getroffen werden. Der Transport darf nur in ESD-gerechten Behältnissen durchgeführt werden. Die Verpackung der Baugruppen muss ESD-konform sein. Verwenden Sie nach Möglichkeit die Verpackung des Ersatzteils oder wählen Sie selber eine ESD-gerechte Verpackung.

Beachten Sie beim Einbau des Ersatzteils die gleichen Vorgaben wie oben beschrieben. Achten Sie auf die ordnungsgemäße Montage des Bauteils und aller Komponenten. Versetzen Sie vor der Inbetriebnahme die Verkabelung wieder in den ursprünglichen Zustand. Fragen Sie im Zweifel beim Hersteller nach weiteren Informationen.

Analysing defective assemblies is an essential part of quality assurance at Bühler Technologies.

To ensure conclusive analysis the goods must be inspected unaltered, if possible. Modifications or other damages which may hide the cause or render it impossible to analyse are prohibited.

Electronic assemblies may be sensitive to static electricity. Be sure to handle these assemblies in an ESD-safe manner. Where possible, the assemblies should be replaced in an ESD-safe location. If unable to do so, take ESD-safe precautions when replacing these. Must be transported in ESD-safe containers. The packaging of the assemblies must be ESD-safe. If possible, use the packaging of the spare part or use ESD-safe packaging.

Observe the above specifications when installing the spare part. Ensure the part and all components are properly installed. Return the cables to the original state before putting into service. When in doubt, contact the manufacturer for additional information.

